



KENR6017-04 (en-us)
August 2018



Disassembly and Assembly

16M Motor Grader Engine Supplement

B9H 1-UP (Machine)
R9H 1-99999 (Machine)

Important Safety Information

Most accidents that involve product operation, maintenance and repair are caused by failure to observe basic safety rules or precautions. An accident can often be avoided by recognizing potentially hazardous situations before an accident occurs. A person must be alert to potential hazards, including human factors that can affect safety. This person should also have the necessary training, skills and tools to perform these functions properly.

Improper operation, lubrication, maintenance or repair of this product can be dangerous and could result in injury or death.

Do not operate or perform any lubrication, maintenance or repair on this product, until you verify that you are authorized to perform this work, and have read and understood the operation, lubrication, maintenance and repair information.

Safety precautions and warnings are provided in this manual and on the product. If these hazard warnings are not heeded, bodily injury or death could occur to you or to other persons.

The hazards are identified by the "Safety Alert Symbol" and followed by a "Signal Word" such as "DANGER", "WARNING" or "CAUTION". The Safety Alert "WARNING" label is shown below.



The meaning of this safety alert symbol is as follows:

Attention! Become Alert! Your Safety is Involved.

The message that appears under the warning explains the hazard and can be either written or pictorially presented.

A non-exhaustive list of operations that may cause product damage are identified by "NOTICE" labels on the product and in this publication.

Caterpillar cannot anticipate every possible circumstance that might involve a potential hazard. The warnings in this publication and on the product are, therefore, not all inclusive. You must not use this product in any manner different from that considered by this manual without first satisfying yourself that you have considered all safety rules and precautions applicable to the operation of the product in the location of use, including site-specific rules and precautions applicable to the worksite. If a tool, procedure, work method or operating technique that is not specifically recommended by Caterpillar is used, you must satisfy yourself that it is safe for you and for others. You should also ensure that you are authorized to perform this work, and that the product will not be damaged or become unsafe by the operation, lubrication, maintenance or repair procedures that you intend to use.

The information, specifications, and illustrations in this publication are on the basis of information that was available at the time that the publication was written. The specifications, torques, pressures, measurements, adjustments, illustrations, and other items can change at any time. These changes can affect the service that is given to the product. Obtain the complete and most current information before you start any job. Cat dealers have the most current information available.



When replacement parts are required for this product Caterpillar recommends using Cat replacement parts.

Failure to follow this warning may lead to premature failures, product damage, personal injury or death.

In the United States, the maintenance, replacement, or repair of the emission control devices and systems may be performed by any repair establishment or individual of the owner's choosing.

Table of Contents

Place a do not operate tag at the battery disconnect switch location to inform personnel that the machine is being worked on.

Disassembly and Assembly Section

Battery - Remove and Install4
 Engine Enclosure (Hood) - Remove.....5
 Engine Enclosure (Hood) - Install8
 Air Cleaner - Remove and Install 12
 Turbocharger - Remove and Install 13
 Muffler - Remove and Install 14
 Alternator - Remove and Install 15
 Vibration Damper and Pulley - Remove and Install 17
 Engine Support (Front) - Remove and Install 19
 Refrigerant Compressor - Remove and Install 21
 Refrigerant Condenser - Remove 24
 Refrigerant Condenser - Install 28
 Fuel Transfer Pump - Remove and Install 31
 Engine Oil Filter Base - Remove.....33
 Engine Oil Filter Base - Disassemble 35
 Engine Oil Filter Base - Assemble 36
 Engine Oil Filter Base - Install 38
 Engine Oil Cooler - Remove and Install 40
 Fuel Priming Pump and Water Separator - Remove and Install 42
 Water Pump - Remove 43
 Water Pump - Install 46
 Fuel Filter (Secondary) and Fuel Filter Base - Remove and Install 48
 Electric Starting Motor - Remove and Install 49
 Radiator Guard and Support, Aftercooler, Hydraulic Oil Cooler, and Radiator - Remove 52
 Aftercooler - Remove and Install 55
 Radiator Guard and Support, Aftercooler, Hydraulic Oil Cooler, and Radiator, - Install..... 59
 Radiator - Remove 62
 Radiator - Install 64
 Rear Chassis Support - Remove 66
 Rear Chassis Support - Install 70
 Flywheel and Rear Gear Group - Remove and Install (Drive Gear) 73
 Rear Gear Group - Remove and Install 77
 Flywheel Housing - Remove and Install 81
 Engine - Remove 83
 Engine - Install 88

Index Section

Index..... 92



Accidental machine starting can cause injury or death to personnel working on the machine.

To avoid accidental machine starting, turn the battery disconnect switch to the OFF position and remove the key. If the machine is not equipped with a battery disconnect switch, disconnect the battery cables from the battery and tape the battery clamps.

Disassembly and Assembly Section

i02728880

Battery - Remove and Install

SMCS Code: 1401-010

Removal Procedure

⚠ WARNING

Personal injury can result from failure to disconnect the battery.

First, disconnect the negative battery cable. Then, disconnect the positive battery cable.

A positive power lead can cause sparks if the battery is not disconnected. Sparks can possibly result in battery explosion or fire.

1. Turn the key for the battery disconnect switch to the OFF position. Remove the key.

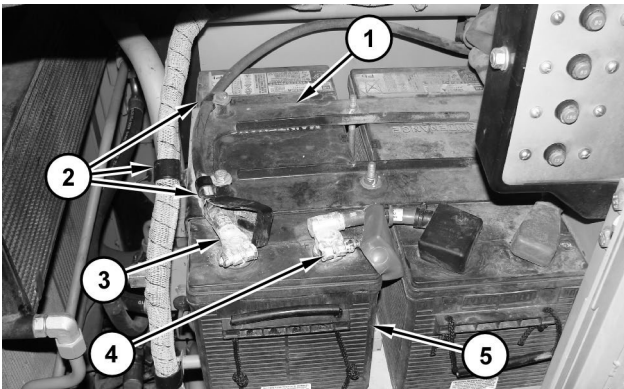

Illustration 1

g01368523

2. Remove hold-down (1). Remove clips (2). Disconnect cable assembly (3). Disconnect cable assembly (4). Use two people in order to remove battery (5). The weight of battery (5) is approximately 54 kg (120 lb).

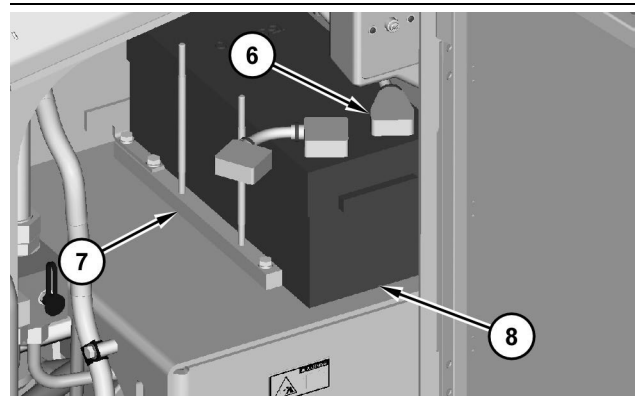

Illustration 2

g01368532

3. Disconnect cable assembly (6). Remove block (7). Use two people in order to remove battery (8). The weight of battery (8) is approximately 54 kg (120 lb).

Installation Procedure

⚠ WARNING

Personal injury can result from failure to disconnect the battery.

First, disconnect the negative battery cable. Then, disconnect the positive battery cable.

A positive power lead can cause sparks if the battery is not disconnected. Sparks can possibly result in battery explosion or fire.

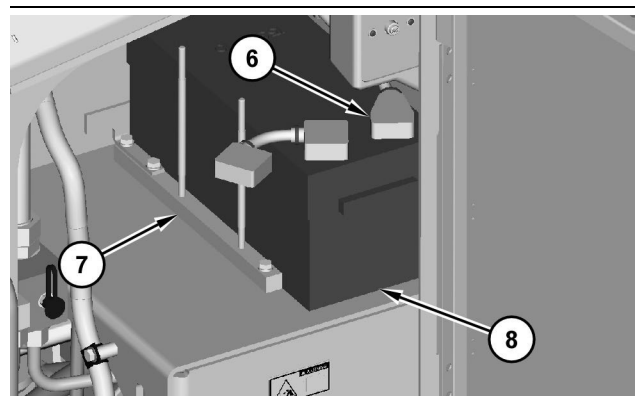

Illustration 3

g01368532

1. Use two people in order to install battery (8). The weight of battery (8) is approximately 54 kg (120 lb). Install block (7). Connect cable assembly (6).

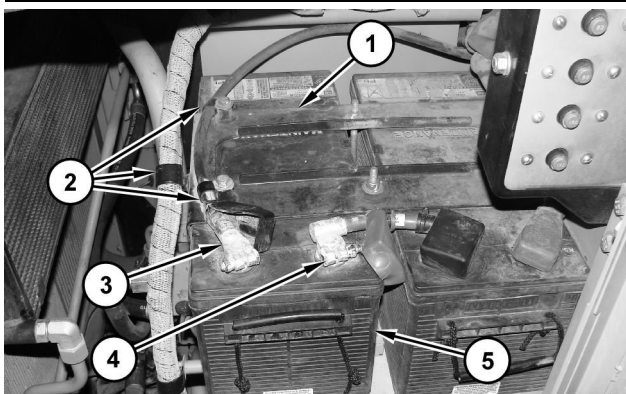

Illustration 4 g01368523

2. Use two people in order to install battery (5). The weight of battery (5) is approximately 54 kg (120 lb). Connect cable assembly (4). Connect cable assembly (3). Install clips (2). Install hold-down (1).
3. Install the key. Turn the battery disconnect switch to the ON position.

i06584448

Engine Enclosure (Hood) - Remove

SMCS Code: 7251-011

Removal Procedure

Table 1

Required Tools			
Tool	Part Number	Part Description	Qty
A	1U-9200	Lever Puller Hoist	1

Start By:

- a. Remove the air cleaner. Refer to Disassembly and Assembly, "Air Cleaner - Remove and Install".

NOTICE

Care must be taken to ensure that fluids are contained during performance of inspection, maintenance, testing, adjusting, and repair of the product. Be prepared to collect the fluid with suitable containers before opening any compartment or disassembling any component containing fluids.

Refer to Special Publication, NENG2500, "Dealer Service Tool Catalog" for tools and supplies suitable to collect and contain fluids on Cat® products.

Dispose of all fluids according to local regulations and mandates.

1. Drain the engine coolant into a suitable container for storage or disposal. Refer to Operation and Maintenance Manual, "Cooling System Extended Life Coolant - Change".



Illustration 5 g01370376

2. Remove panel (1). Repeat this step for the opposite side.

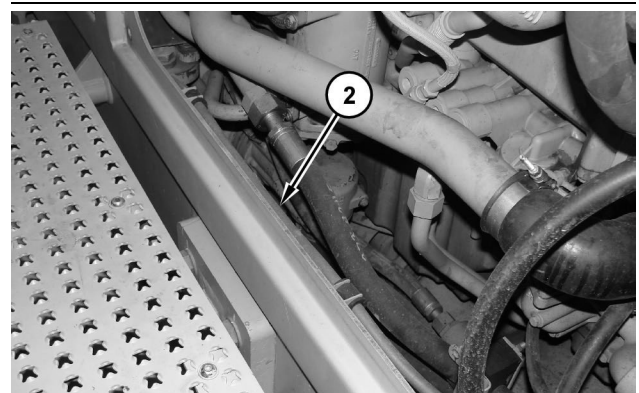

Illustration 6 g01370382

3. Position cable assembly (2) out of the way.

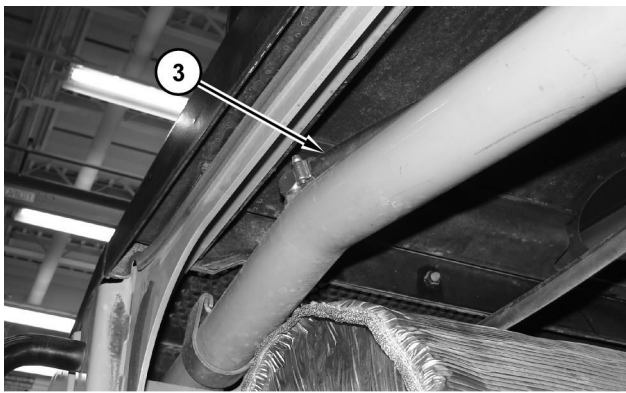

Illustration 7

g01370391

4. Disconnect hose (3).

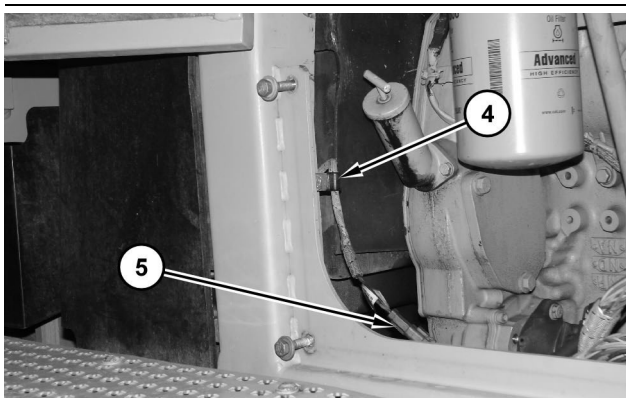

Illustration 8

g01370395

5. Remove clip (4). Disconnect harness assembly (5).

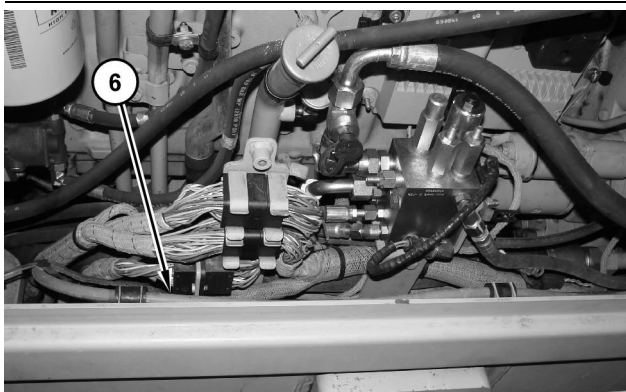

Illustration 9

g01370397

6. Position cable assembly (6) out of the way.

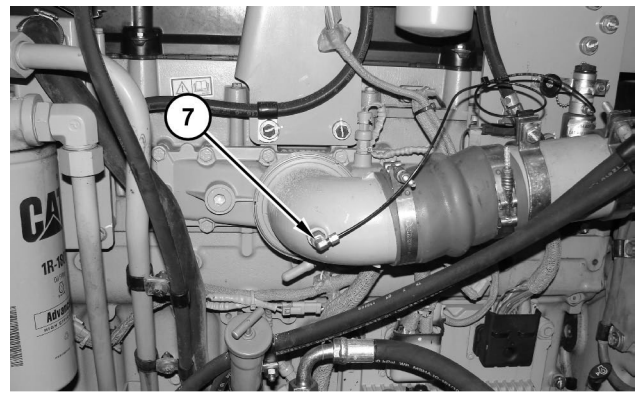

Illustration 10

g01371016

7. Disconnect fitting (7).



Illustration 11

g01371019

8. Remove guard assembly (8).

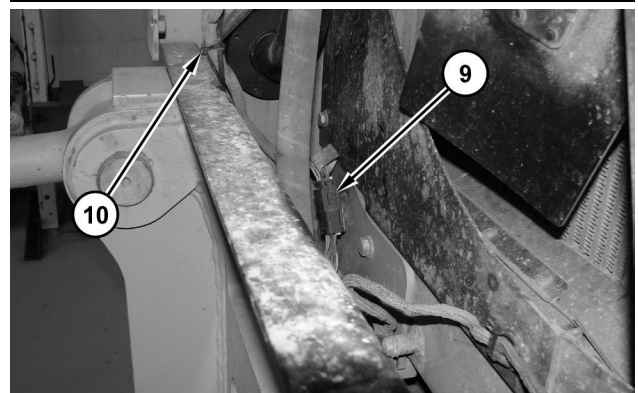

Illustration 12

g01371026

9. Disconnect harness assembly (9). Remove cable straps (10).

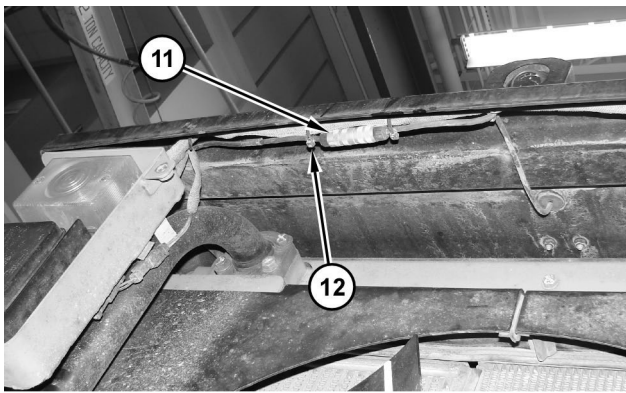

Illustration 13 g01371037

10. Disconnect cable assembly (11). Remove cable straps (12).

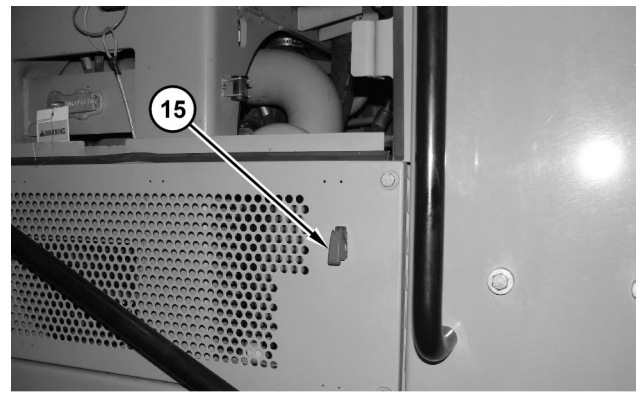

Illustration 16 g01371083

13. Disconnect switch assembly (15).

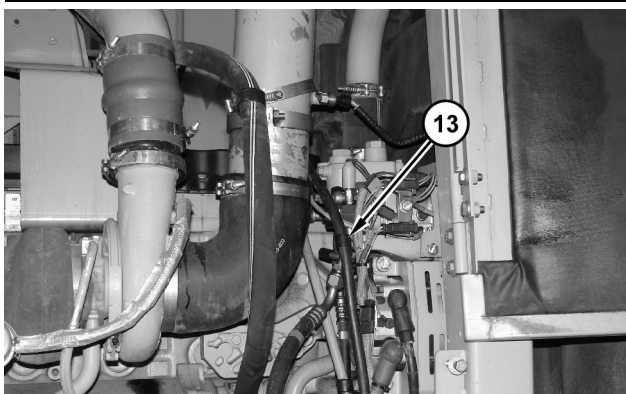

Illustration 14 g01371058

11. Remove clip (13).

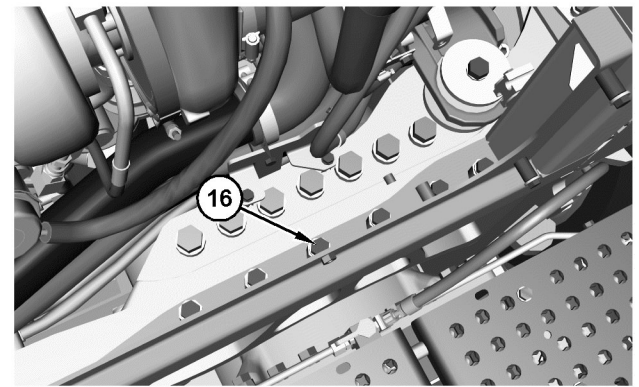

Illustration 17 g06033577

14. Remove bolts (16). Repeat this step for the opposite side.

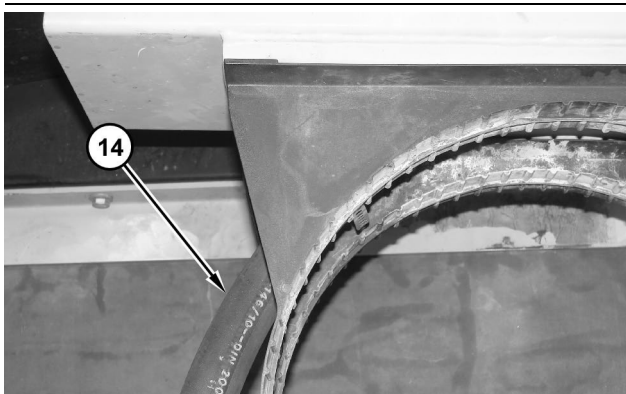

Illustration 15 g01371065

12. Disconnect hose (14).

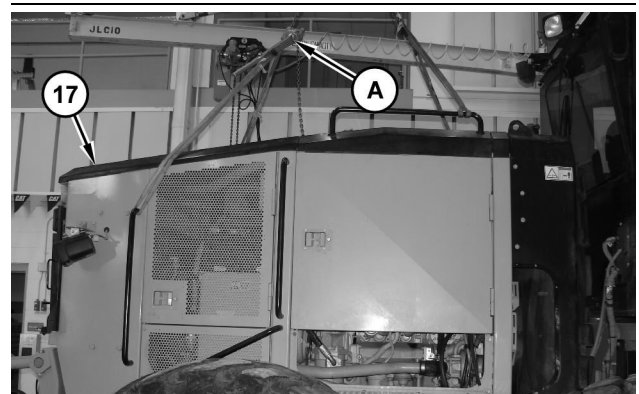

Illustration 18 g01371102

15. Attach Tooling (A) and a suitable lifting device onto engine enclosure (17). The weight of engine enclosure (17) is approximately 527 kg (1162 lb).

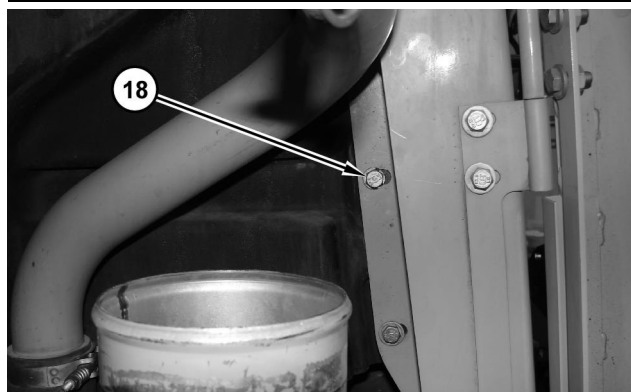

Illustration 19 g01371105

16. Remove bolts (18). Repeat this step for the opposite side.

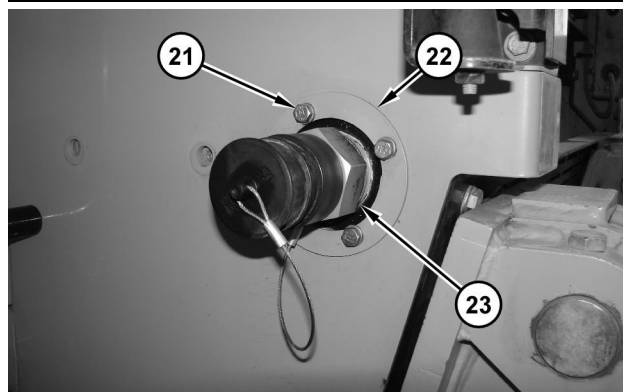

Illustration 22 g01371129

19. Remove bolts (21). Remove plate (22). Remove connector (23).

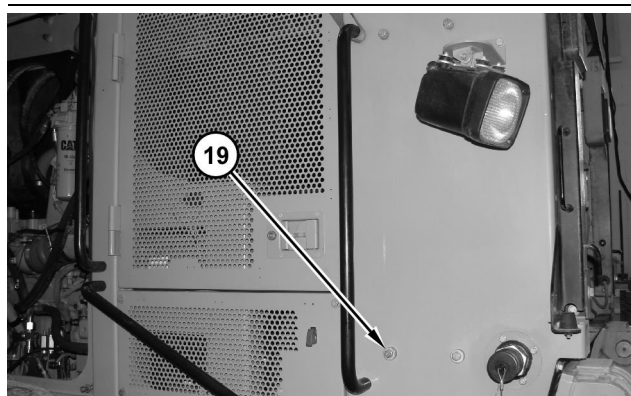

Illustration 20 g01371108

17. Remove bolts (19). Repeat this step for the opposite side.



Illustration 23 g01371130

20. Remove engine enclosure (17).

i06584487

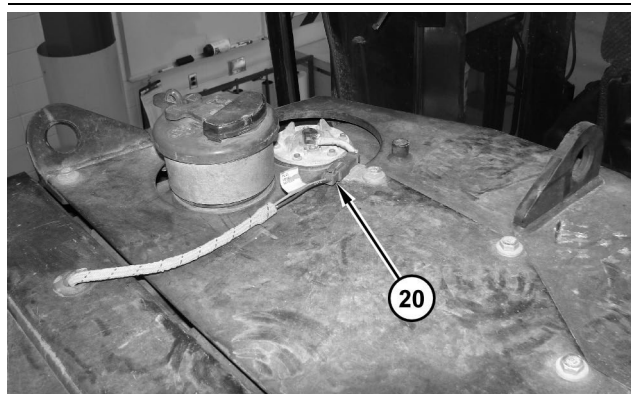

Illustration 21 g01371125

18. Disconnect harness assembly (20).

Engine Enclosure (Hood) - Install

SMCS Code: 7251-012

Installation Procedure

Table 2

Required Tools			
Tool	Part Number	Part Description	Qty
A	1U-9200	Lever Puller Hoist	1

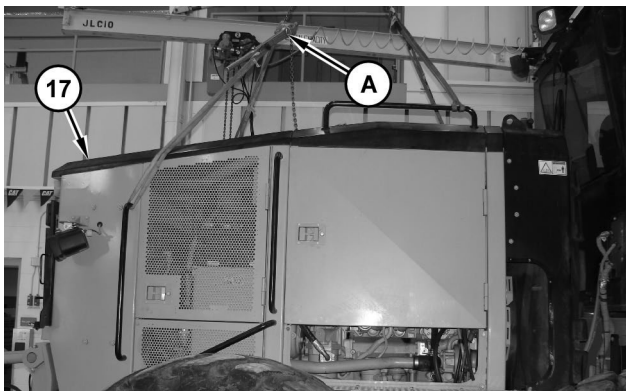

Illustration 24 g01371102

1. Use Tooling (A) and a suitable lifting device to install engine enclosure (17). The weight of engine enclosure (17) is approximately 527 kg (1162 lb).

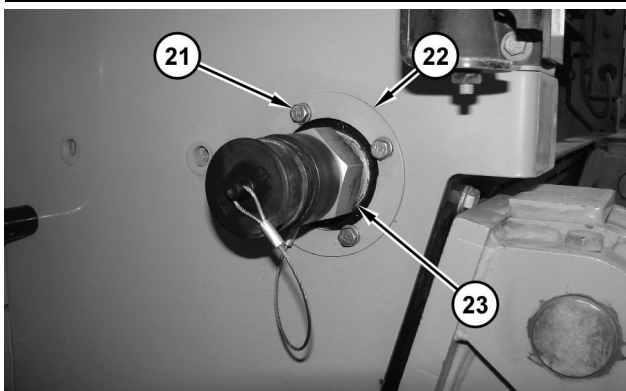

Illustration 25 g01371129

2. Install connector (23). Install plate (22). Install bolts (21).

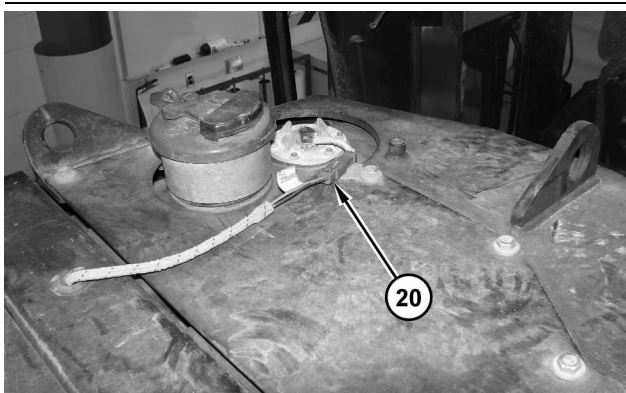

Illustration 26 g01371125

3. Connect harness assembly (20).

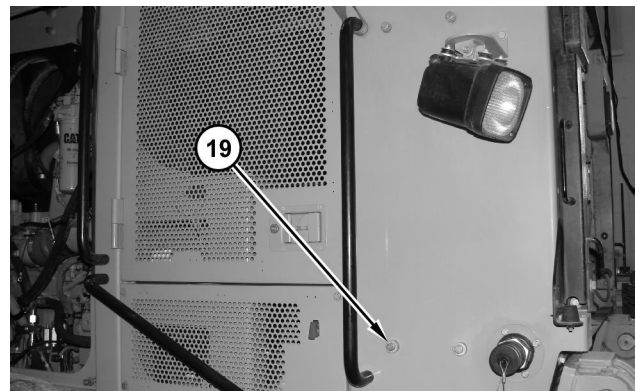

Illustration 27 g01371108

4. Install bolts (19). Repeat this step for the opposite side.

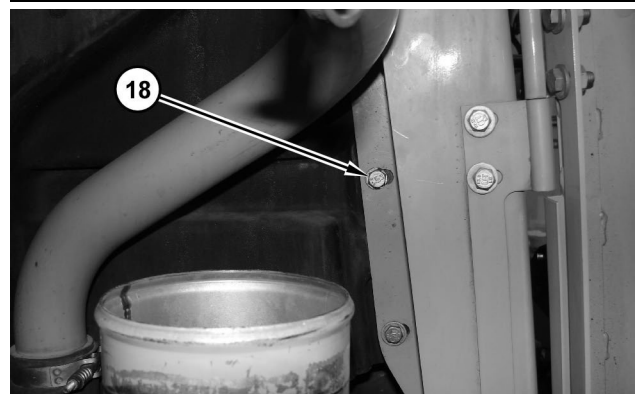

Illustration 28 g01371105

5. Install bolts (18). Repeat this step for the opposite side.

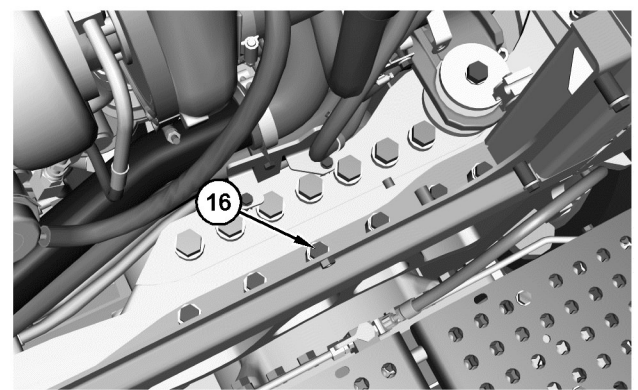

Illustration 29 g06033577

6. Install bolts (16). Repeat this step for the opposite side.

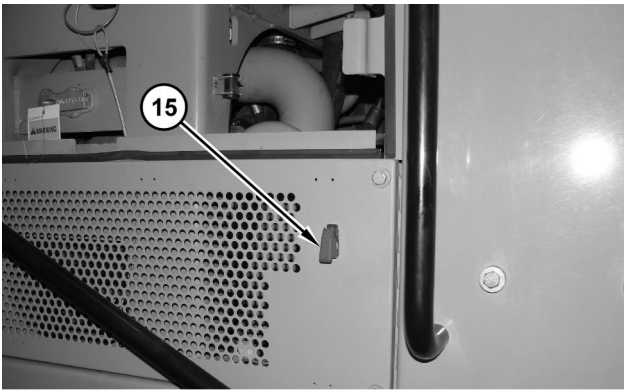

Illustration 30

g01371083

7. Connect switch assembly (15).

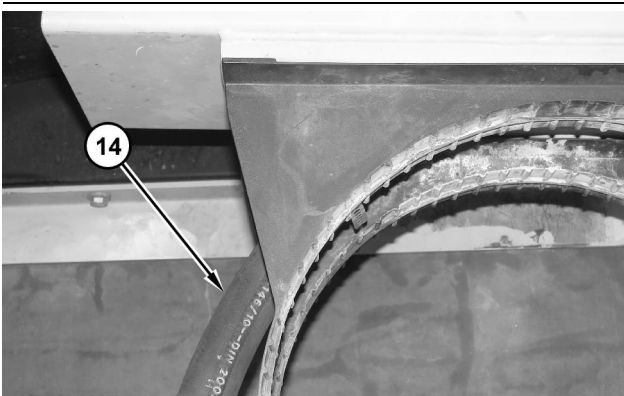

Illustration 31

g01371065

8. Connect hose (14).

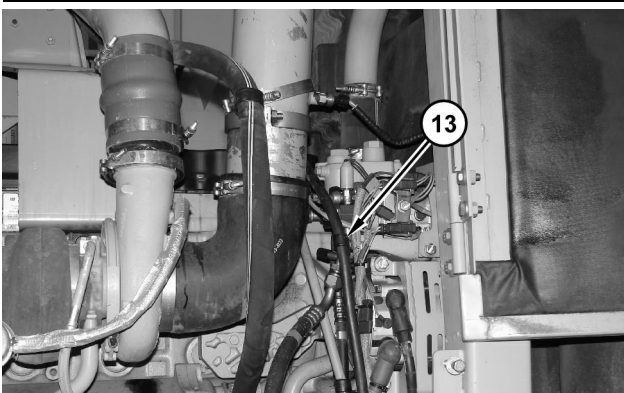

Illustration 32

g01371058

9. Install clip (13).

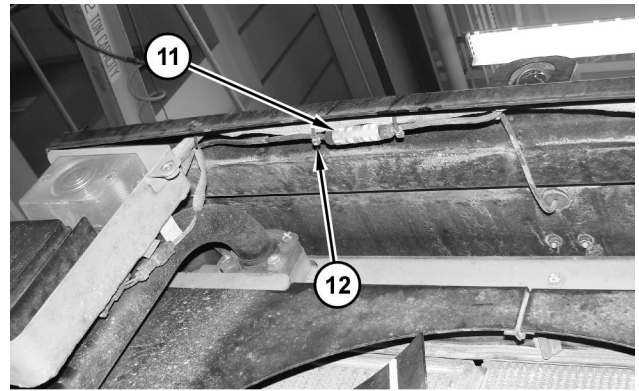

Illustration 33

g01371037

10. Connect cable assembly (11). Install cable straps (12).

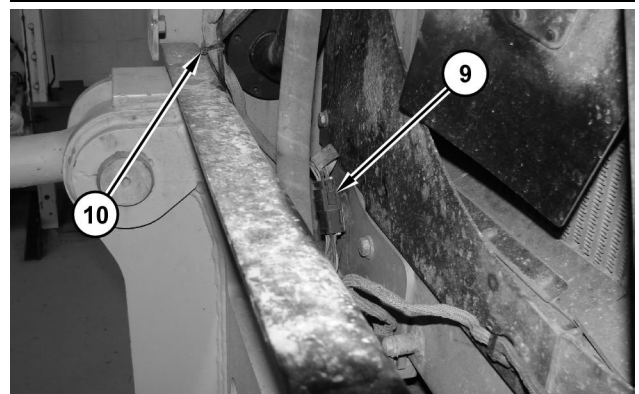

Illustration 34

g01371026

11. Install cable straps (10). Connect harness assembly (9).



Illustration 35

g01371019

12. Install guard assembly (8).

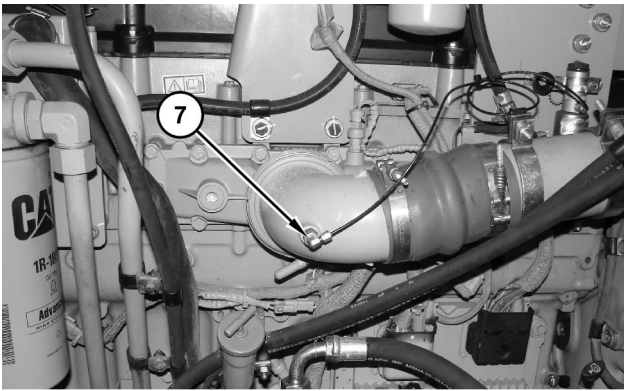

Illustration 36

g01371016

13. Connect fitting (7).

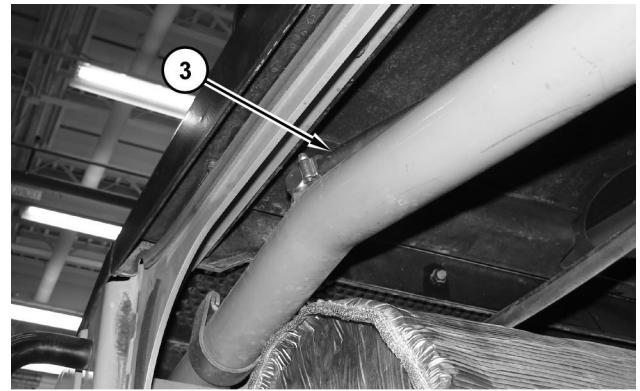

Illustration 39

g01370391

16. Connect hose (3).

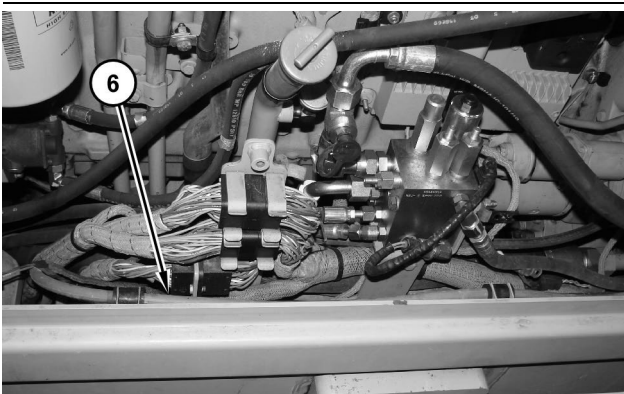

Illustration 37

g01370397

14. Position cable assembly (6).

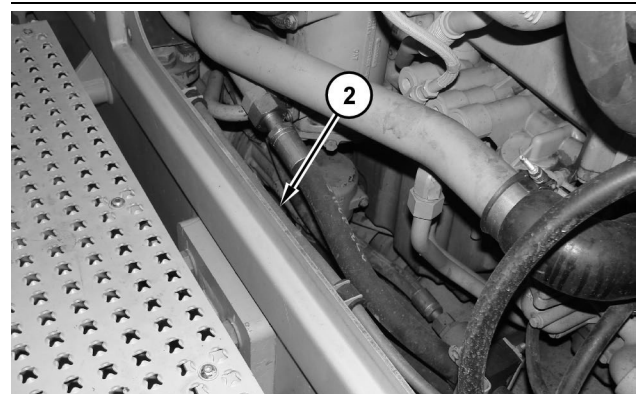

Illustration 40

g01370382

17. Position cable assembly (2).

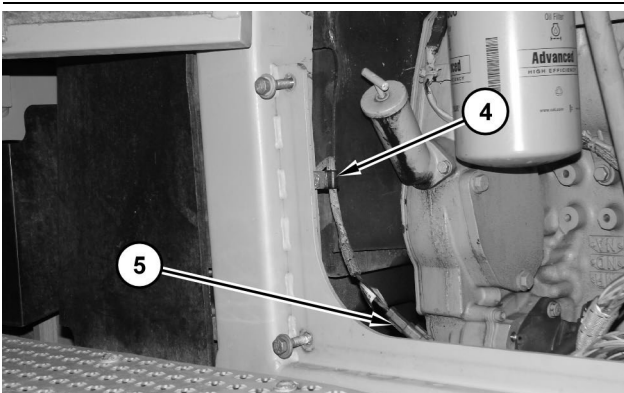

Illustration 38

g01370395

15. Connect harness assembly (5). Install clip (4).



Illustration 41

g01370376

18. Install panel (1). Repeat this step for the opposite side.

19. Fill the engine coolant. Refer to Operation and Maintenance Manual, "Cooling System Extended Life Coolant - Change".

End By:

- a. Install the air cleaner. Refer to Disassembly and Assembly, "Air Cleaner - Remove and Install".

i02729009

Air Cleaner - Remove and Install

SMCS Code: 1051-010-HG; 1054-010

Removal Procedure

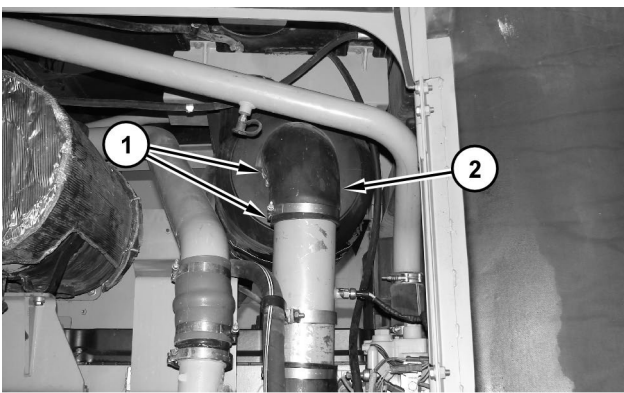

Illustration 42

g01368574

1. Disconnect clamps (1) in order to remove hose (2).

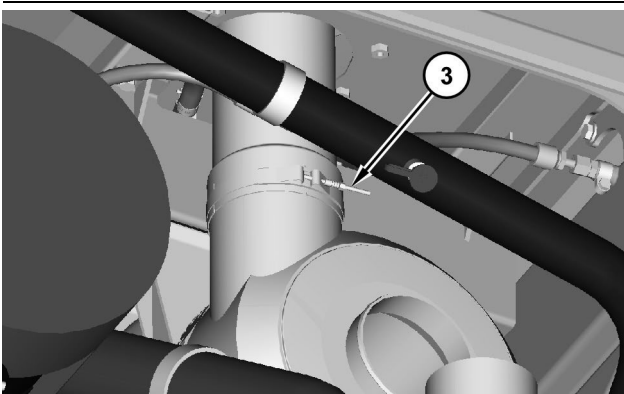

Illustration 43

g01368576

2. Loosen clamp (3).

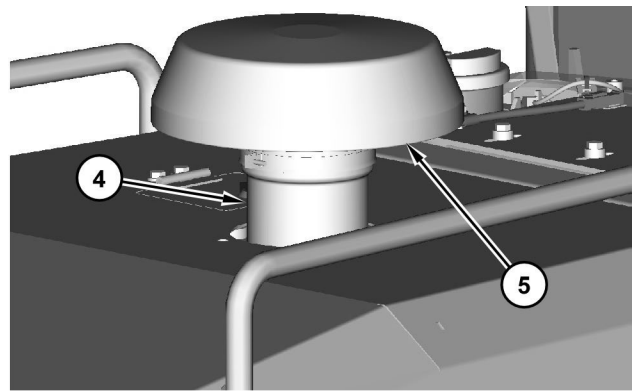

Illustration 44

g01368593

3. Remove extension pipe (4) and cover (5).

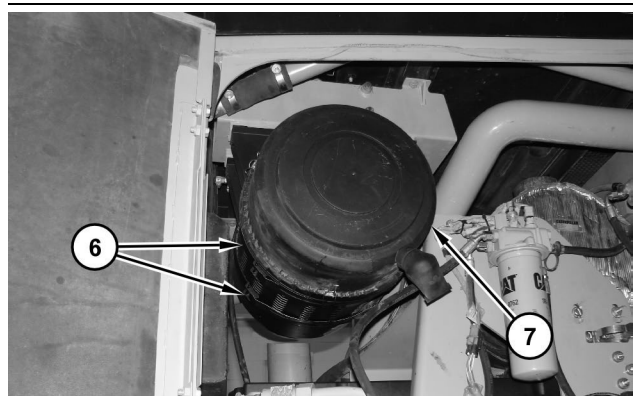

Illustration 45

g01368597

4. Disconnect clamps (6). Remove air cleaner (7).

Installation Procedure

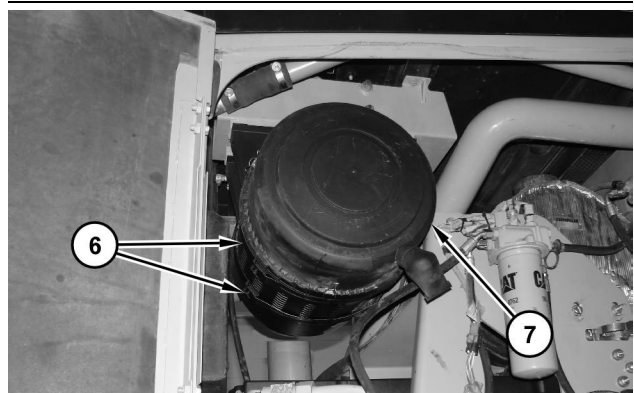

Illustration 46

g01368597

1. Install air cleaner (7). Connect clamps (6).

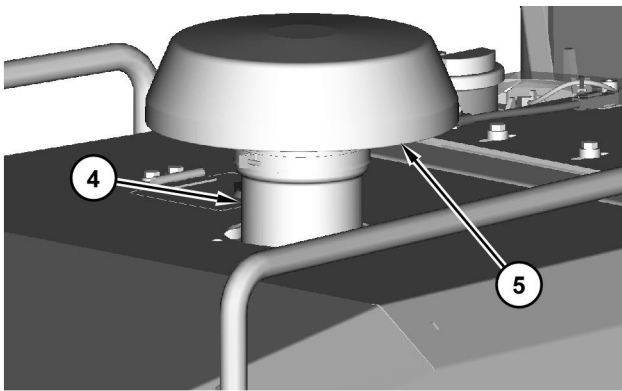

Illustration 47

g01368593

2. Install extension pipe (4) and cover (5).

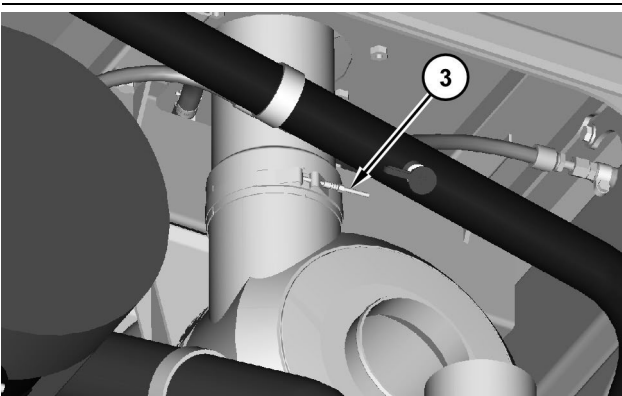

Illustration 48

g01368576

3. Tighten clamp (3).

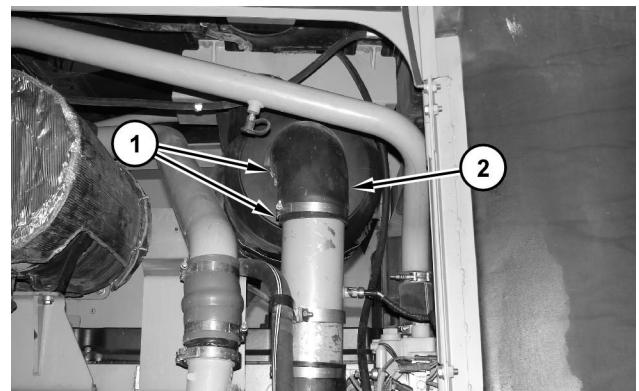

Illustration 49

g01368574

4. Install hose (2). Connect clamps (1).

i02764428

Turbocharger - Remove and Install

SMCS Code: 1052-010

Removal Procedure

NOTICE

Keep all parts clean from contaminants.

Contaminants may cause rapid wear and shortened component life.

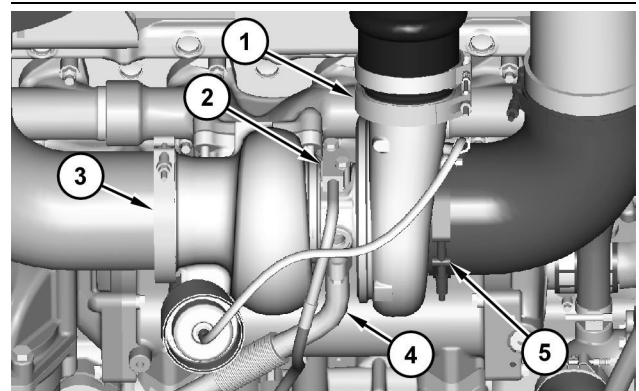

Illustration 50

g01383819

1. Disconnect clamps (1). Disconnect tube assembly (2). Disconnect clamp (3). Disconnect tube assembly (4). Disconnect clamp (5).

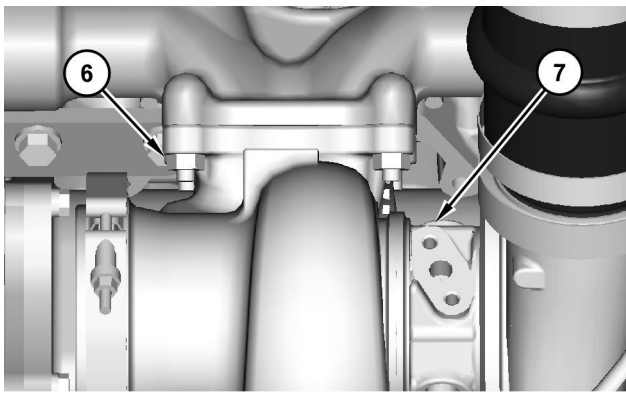

Illustration 51

g01383820

- Remove nuts (6). Remove turbocharger (7) and the gasket.

Installation Procedure

Table 3

Required Tools			
Tool	Part Number	Part Description	Qty
A	4C-5597	Anti-Seize Compound	1

NOTICE

Keep all parts clean from contaminants.

Contaminants may cause rapid wear and shortened component life.

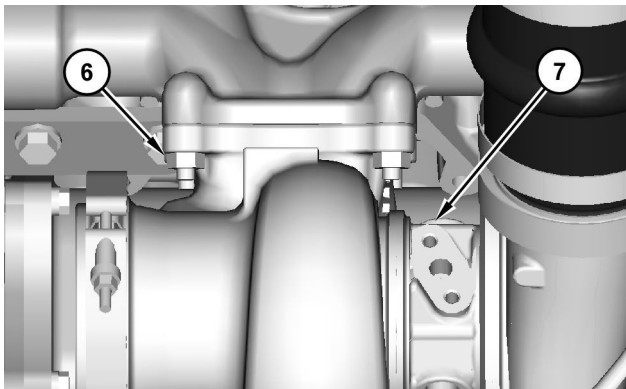

Illustration 52

g01383820

- Apply Tooling (A) onto nuts (6) and the studs. Position the gasket onto the studs. Install turbocharger (7). Install nuts (6). Tighten nuts (6) to a torque of 55 ± 5 N·m (41 ± 4 lb ft).

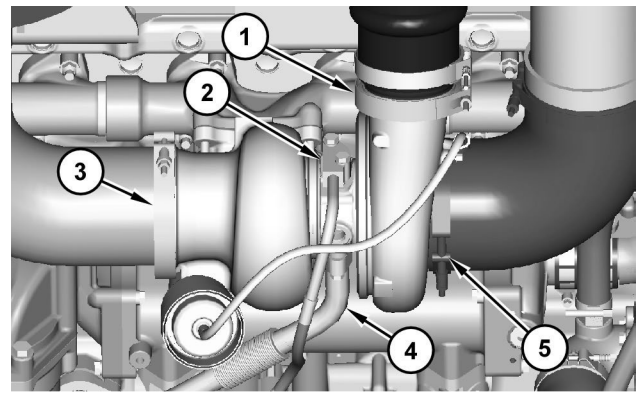

Illustration 53

g01383819

- Connect clamp (5). Connect tube assembly (4). Connect clamp (3). Connect tube assembly (2). Connect clamps (1).

i02728695

Muffler - Remove and Install

SMCS Code: 1062-010

Removal Procedure

WARNING

Hot engine components can cause injury from burns. Before performing maintenance on the engine, allow the engine and the components to cool.

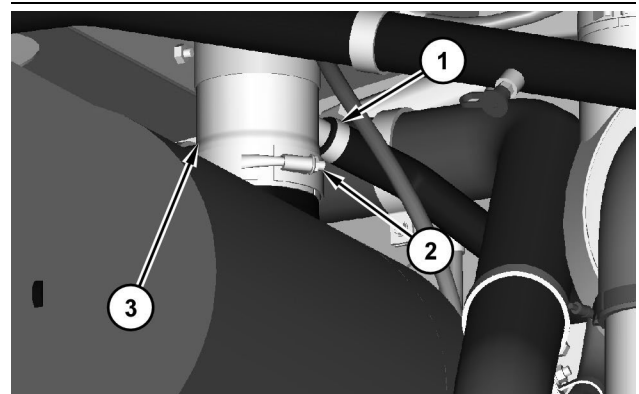

Illustration 54

g01368400

- Disconnect hose (1). Loosen clamp (2). Remove ejector assembly (3).

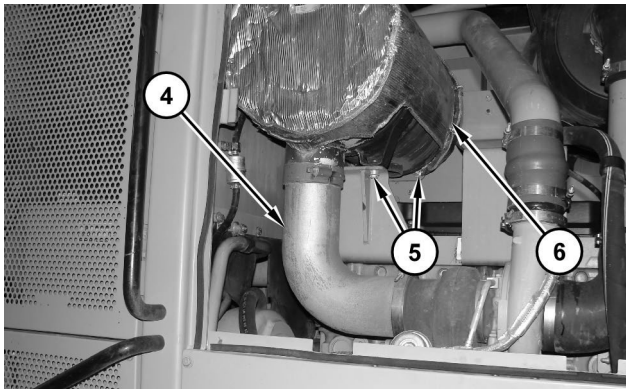

Illustration 55

g01368414

- 2. Disconnect elbow (4). Remove bolts (5). Remove muffler (6).

Installation Procedure

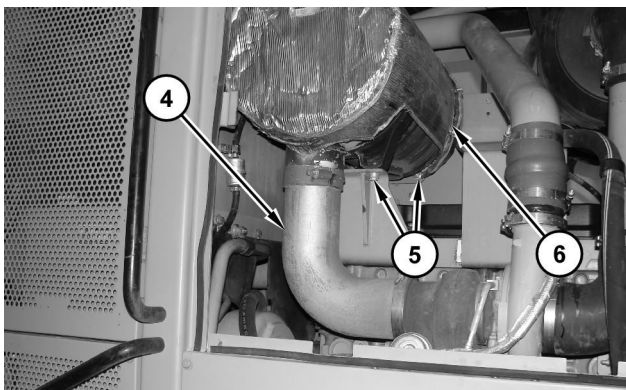

Illustration 56

g01368414

- 1. Install muffler (6). Install bolts (5). Connect elbow (4).

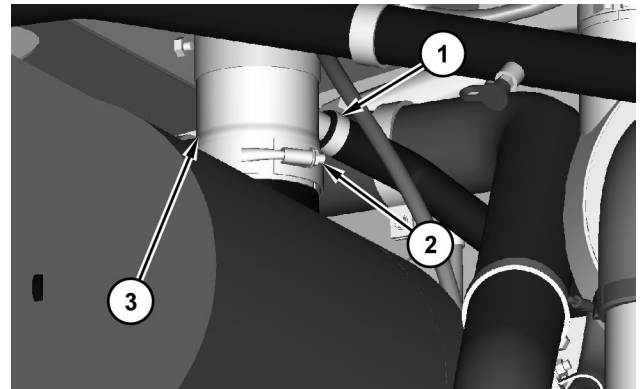

Illustration 57

g01368400

- 2. Install ejector assembly (3). Tighten clamp (2). Connect hose (1).

i02729225

Alternator - Remove and Install

SMCS Code: 1405-010

Removal Procedure

⚠ WARNING

Personal injury can result from failure to disconnect the battery.

First, disconnect the negative battery cable. Then, disconnect the positive battery cable.

A positive power lead can cause sparks if the battery is not disconnected. Sparks can possibly result in battery explosion or fire.

- 1. Turn the key for the battery disconnect switch to the OFF position. Remove the key.

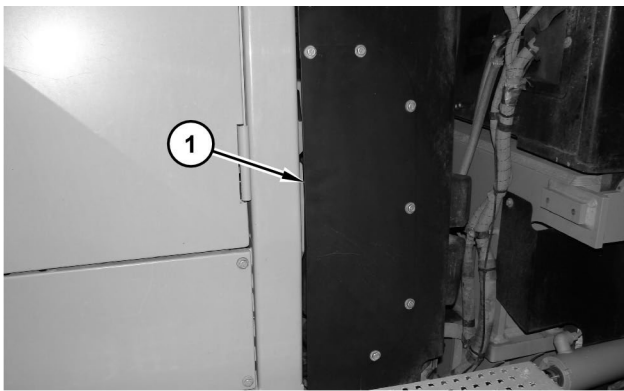

Illustration 58

g01368779

2. Remove panel (1).

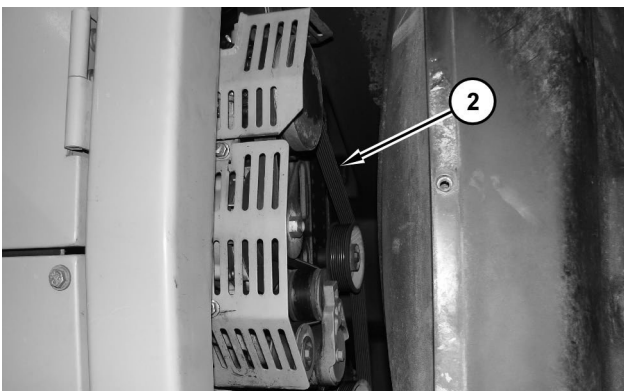

Illustration 59

g01368782

3. Remove belt (2). Refer to Operation and Maintenance Manual, "Belt - Replace".

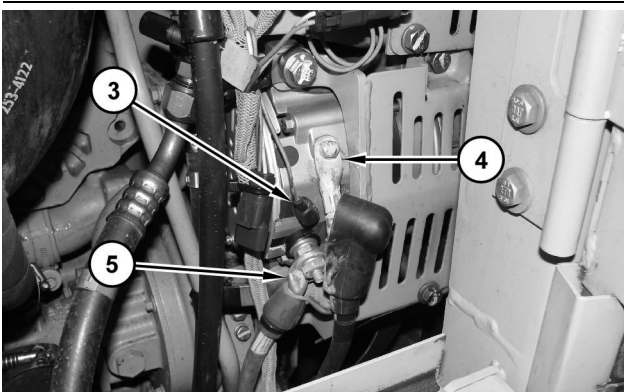

Illustration 60

g01368794

4. Disconnect harness assembly (3). Disconnect cable assembly (4). Disconnect cable assembly (5).

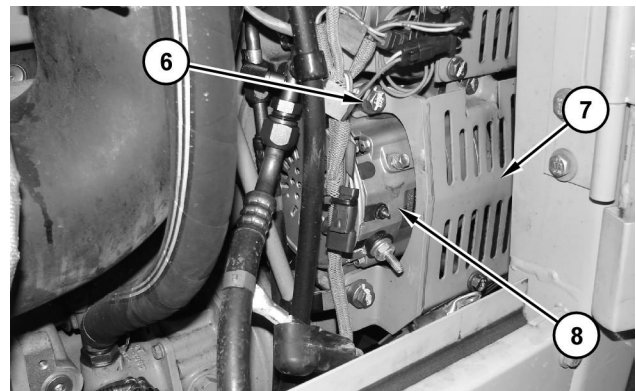

Illustration 61

g01368818

5. Remove bolts (6). Remove guard (7). Remove alternator (8).

Installation Procedure

⚠ WARNING

Personal injury can result from failure to disconnect the battery.

First, disconnect the negative battery cable. Then, disconnect the positive battery cable.

A positive power lead can cause sparks if the battery is not disconnected. Sparks can possibly result in battery explosion or fire.

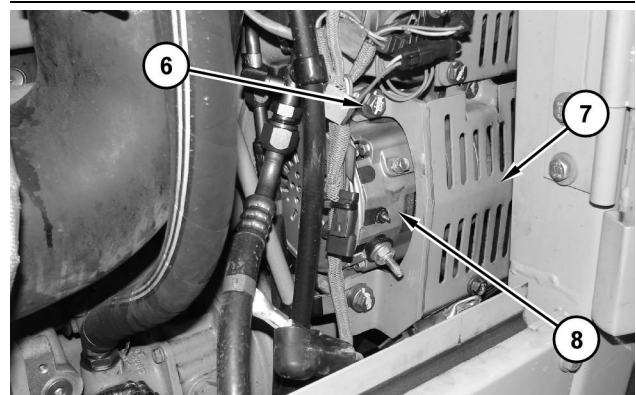

Illustration 62

g01368818

1. Install alternator (8). Install guard (7). Install bolts (6).

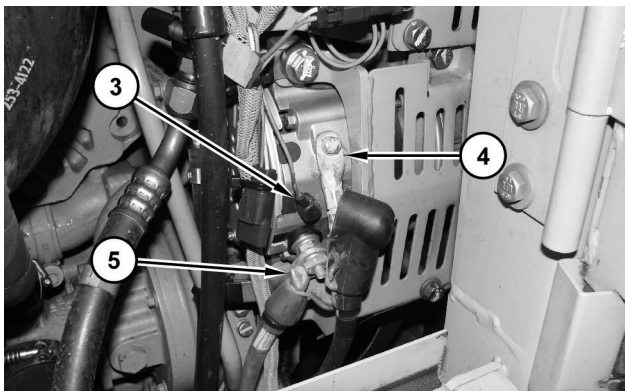

Illustration 63

g01368794

2. Connect cable assembly (5). Connect cable assembly (4). Connect harness assembly (3).

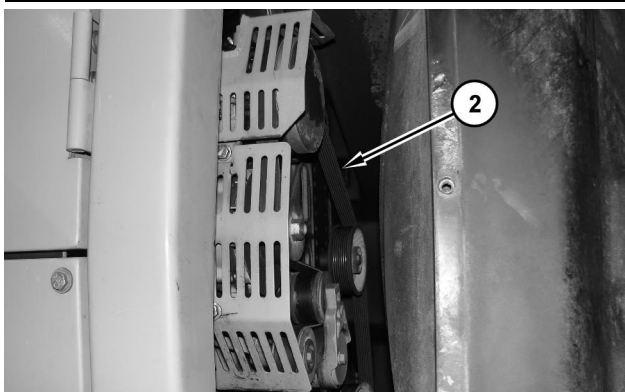

Illustration 64

g01368782

3. Install belt (2). Refer to Operation and Maintenance Manual, "Belt - Replace".

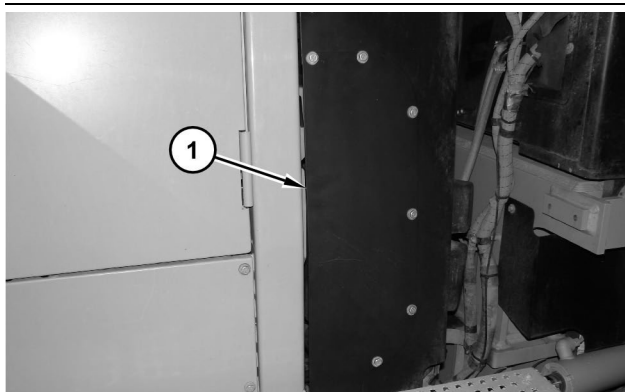

Illustration 65

g01368779

4. Install panel (1).

5. Install the key. Turn the battery disconnect switch to the ON position.

i02764510

Vibration Damper and Pulley - Remove and Install

SMCS Code: 1205-010

Removal Procedure

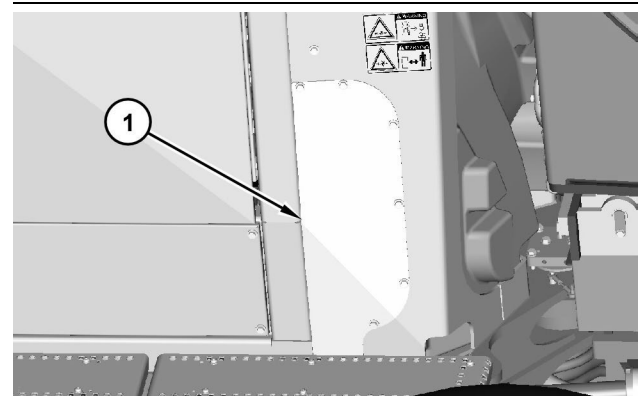

Illustration 66

g01383854

1. Remove panel (1).

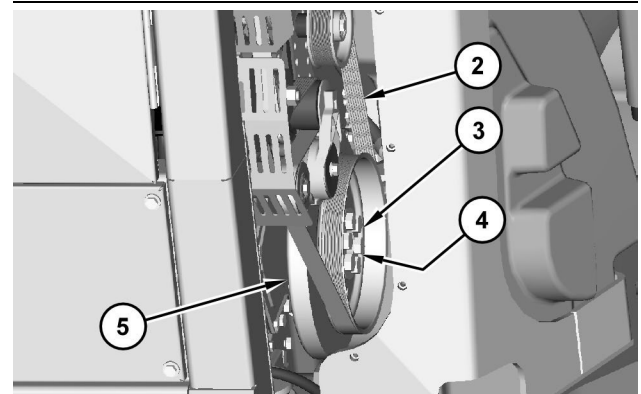

Illustration 67

g01383857

2. Remove belt (2). Refer to Operation and Maintenance Manual, "Belt - Replace".
3. Remove bolts (3) and retainer (4).
4. Use two people in order to remove crankshaft vibration damper and pulley (5). The weight of crankshaft vibration damper and pulley (5) is approximately 27 kg (60 lb).

Installation Procedure

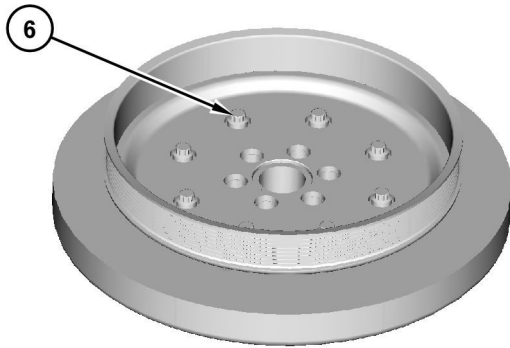

Illustration 68

g01326268

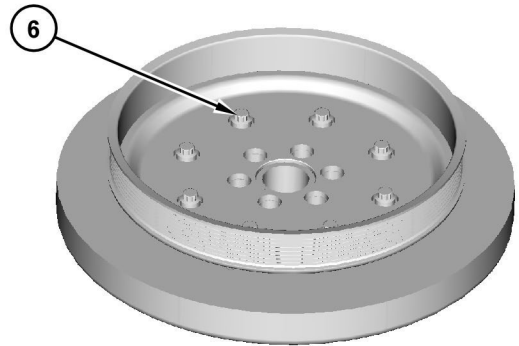

Illustration 70

g01326268

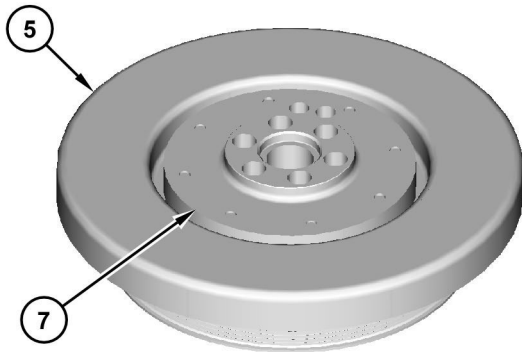

Illustration 69

g01326300

- 5.** Remove bolts (6) in order to remove adapter (7) from crankshaft vibration damper and pulley (5).

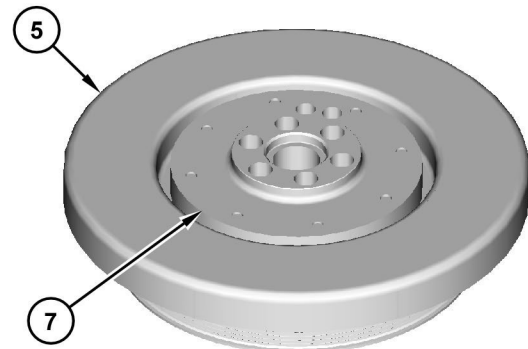

Illustration 71

g01326300

- 1.** Install adapter (7) onto crankshaft vibration damper and pulley (5). Install bolts (6).

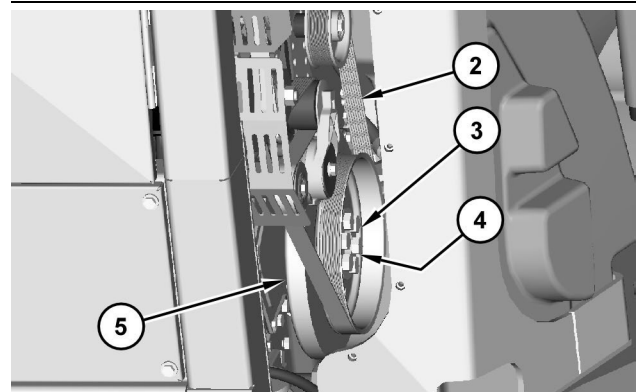

Illustration 72

g01383857

- 2.** Use two people in order to install crankshaft vibration damper and pulley (5). The weight of crankshaft vibration damper and pulley (5) is approximately 27 kg (60 lb).

3. Install retainer (4). Install bolts (3).
4. Install belt (2). Refer to Operation and Maintenance Manual, "Belt - Replace".



Illustration 73

g01383854

5. Install panel (1).

i02764612

Engine Support (Front) - Remove and Install

SMCS Code: 1153-010; 1154-010-FR

Removal Procedure

Start By:

- a. Remove the engine enclosure. Refer to Disassembly and Assembly, "Engine Enclosure (Hood) - Remove".
- b. Remove the fuel tank. Refer to Disassembly and Assembly, "Fuel Tank - Remove".
- c. Remove the vibration damper. Refer to Disassembly and Assembly, "Vibration Damper and Pulley - Remove and Install".

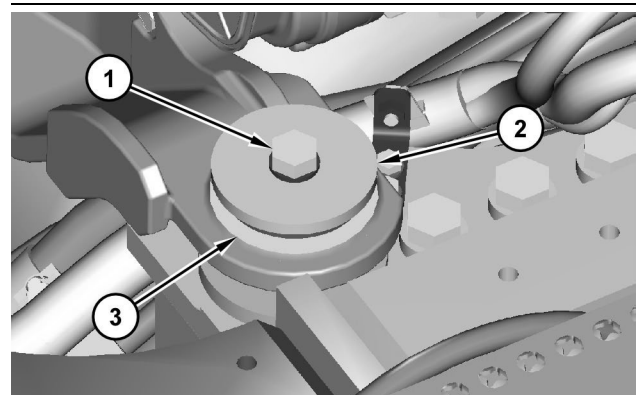

Illustration 74

g01386745

1. Remove bolts (1), washer (2), and mount assembly (3). Repeat this step for the opposite side.

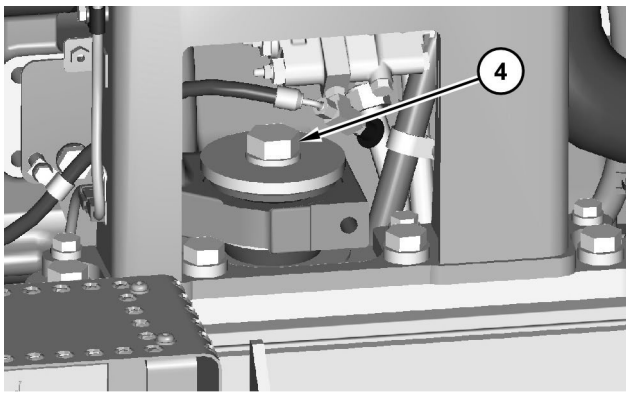

Illustration 75

g01386775

2. Loosen bolt (4). Repeat this step for the opposite side.

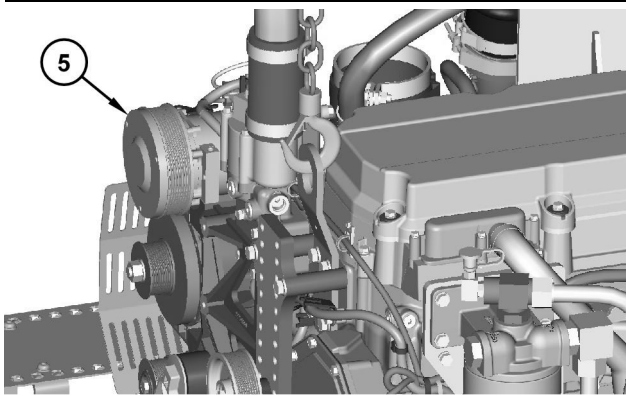

Illustration 76

g01386780

3. Use a suitable lifting device in order to raise the front of engine (5). The weight of engine (5) is approximately 1497 kg (3300 lb).

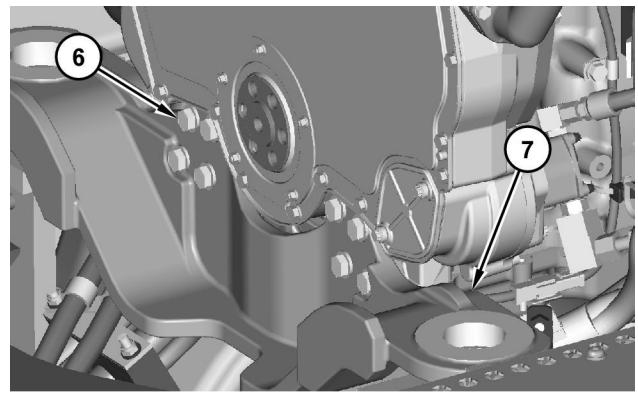

Illustration 77

g01387586

4. Remove bolts (6). Use two people in order to remove front engine support (7). The weight of front engine support (7) is approximately 38 kg (84 lb).

Installation Procedure

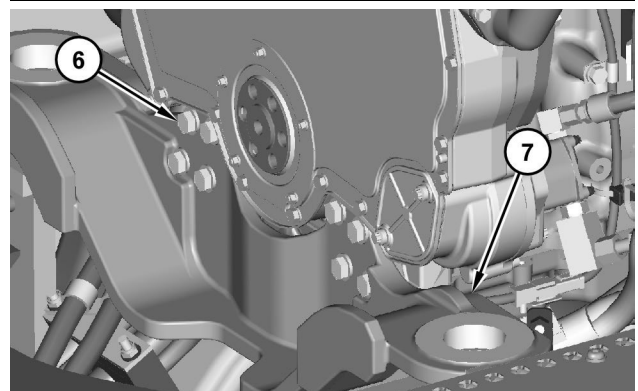

Illustration 78

g01387586

1. Use two people in order to install front engine support (7). The weight of front engine support (7) is approximately 38 kg (84 lb). Install bolts (6).

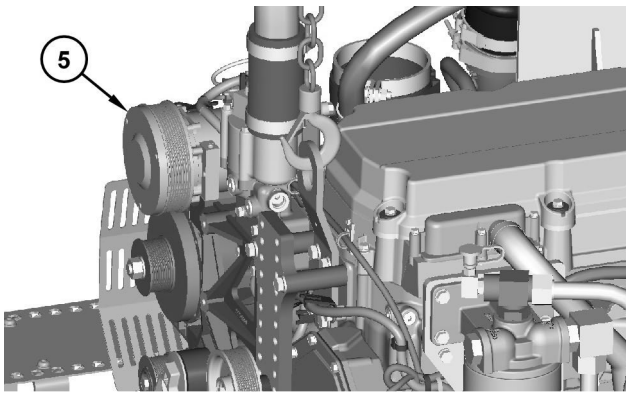

Illustration 79

g01386780

2. Use a suitable lifting device in order to lower the front of engine (5). The weight of engine (5) is approximately 1497 kg (3300 lb).

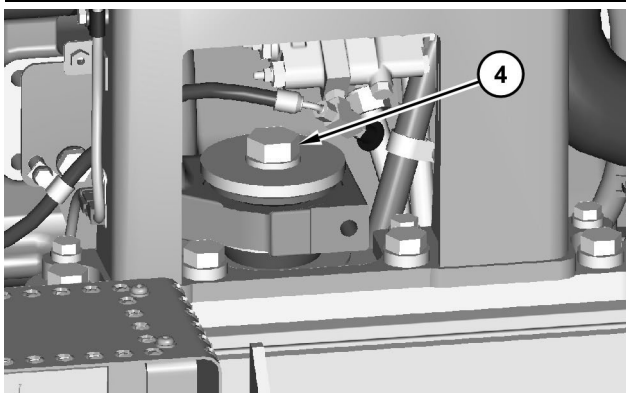

Illustration 80

g01386775

3. Tighten bolt (4). Repeat this step for the opposite side.

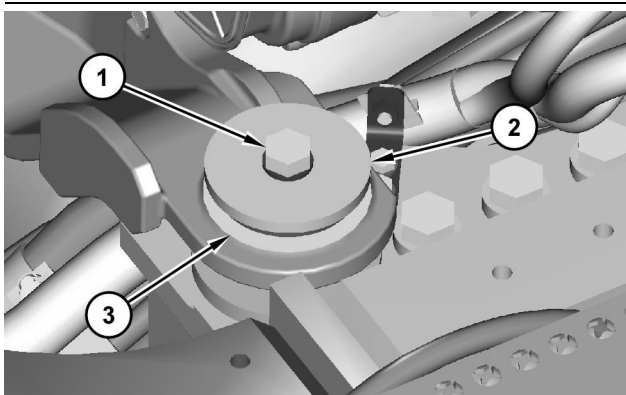

Illustration 81

g01386745

4. Install mount assembly (3), washer (2), and bolt (1). Repeat this step for the opposite side.

End By:

- a. Install the vibration damper. Refer to Disassembly and Assembly, "Vibration Damper and Pulley - Remove and Install".
- b. Install the fuel tank. Refer to Disassembly and Assembly, "Fuel Tank - Install".
- c. Install the engine enclosure. Refer to Disassembly and Assembly, "Engine Enclosure (Hood) - Install".

i02808591

Refrigerant Compressor - Remove and Install

SMCS Code: 1802-010

Removal Procedure

NOTICE

Keep all parts clean from contaminants.

Contaminants may cause rapid wear and shortened component life.

Note: Put identification marks on all lines, on all hoses, on all wires, and on all tubes for installation purposes. Plug all lines, hoses, and tubes. This helps to prevent fluid loss and this helps to keep contaminants from entering the system.

NOTICE

Care must be taken to ensure that fluids are contained during performance of inspection, maintenance, testing, adjusting, and repair of the product. Be prepared to collect the fluid with suitable containers before opening any compartment or disassembling any component containing fluids.

Refer to Special Publication, NENG2500, "Dealer Service Tool Catalog" for tools and supplies suitable to collect and contain fluids on Cat® products.

Dispose of all fluids according to local regulations and mandates.

⚠ WARNING

Personal injury can result from contact with refrigerant.

Contact with refrigerant can cause frost bite. Keep face and hands away to help prevent injury.

Protective goggles must always be worn when refrigerant lines are opened, even if the gauges indicate the system is empty of refrigerant.

Always use precaution when a fitting is removed. Slowly loosen the fitting. If the system is still under pressure, release it slowly in a well ventilated area.

Personal injury or death can result from inhaling refrigerant through a lit cigarette.

Inhaling air conditioner refrigerant gas through a lit cigarette or other smoking method or inhaling fumes released from a flame contacting air conditioner refrigerant gas, can cause bodily harm or death.

Do not smoke when servicing air conditioners or wherever refrigerant gas may be present.

Use a certified recovery and recycling cart to properly remove the refrigerant from the air conditioning system.

1. Recover the air conditioner refrigerant from the air conditioner system. Refer to Service Manual, SENR5664, "Air Conditioning and Heating Systems with R-134a Refrigerant" for the correct procedure. Refer to Dealer Service Tool Catalog, NENG2500, "Air Conditioning Tools" for the correct tools.

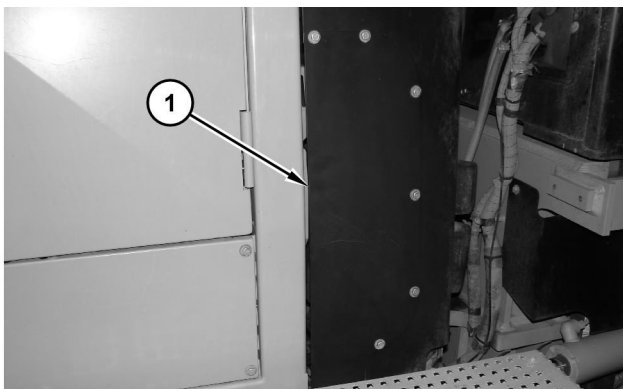

Illustration 82

g01368713

2. Remove panel (1).

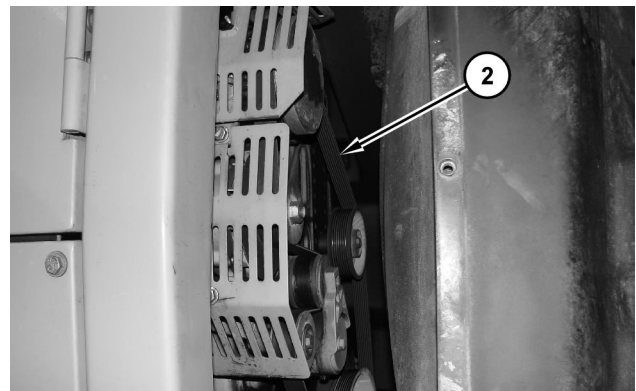

Illustration 83

g01368716

3. Remove belt (2). Refer to Operation and Maintenance Manual, "Belt - Replace".



Illustration 84

g01368718

4. Disconnect harness assemblies (3) and harness assemblies (4).

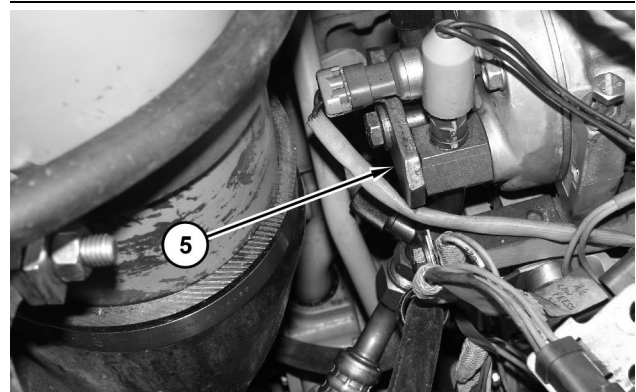

Illustration 85

g01368722

5. Disconnect tube assemblies (5).

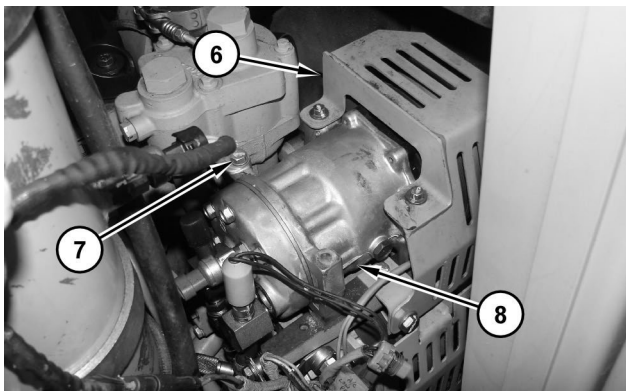

Illustration 86

g01368727

6. Remove guard (6). Remove bolts (7). Remove refrigerant compressor (8).

Installation Procedure

NOTICE

Keep all parts clean from contaminants.

Contaminants may cause rapid wear and shortened component life.

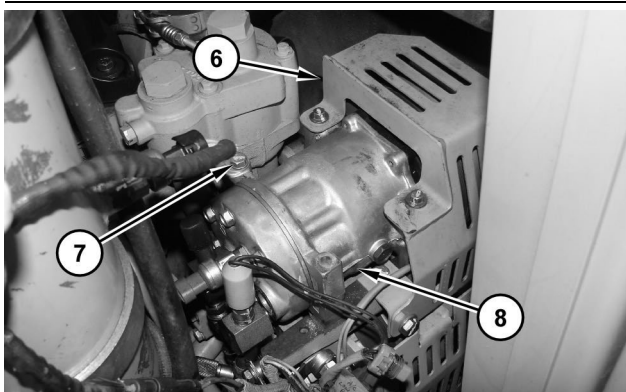

Illustration 87

g01368727

1. Install refrigerant compressor (8). Install bolts (7). Install guard (6).

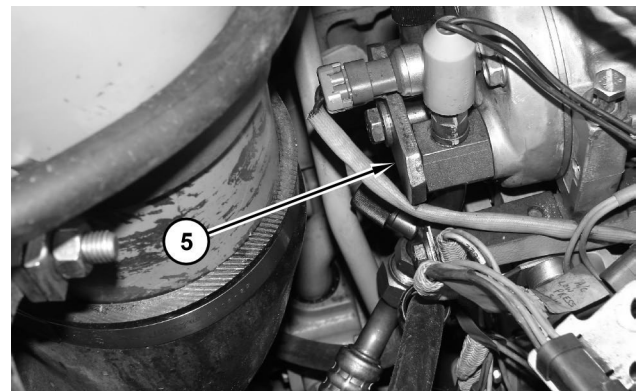

Illustration 88

g01368722

2. Connect tube assemblies (5).

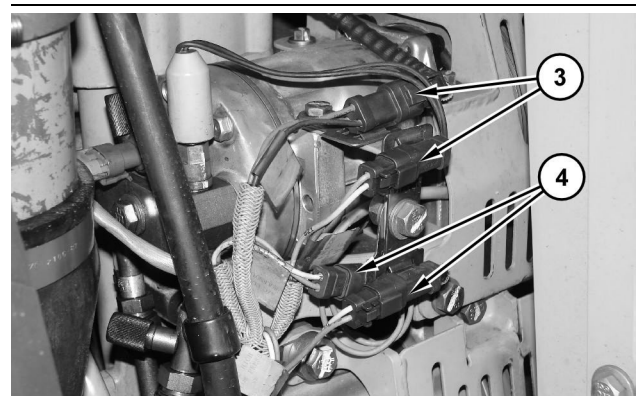

Illustration 89

g01368718

3. Connect harness assemblies (4) and harness assemblies (3).

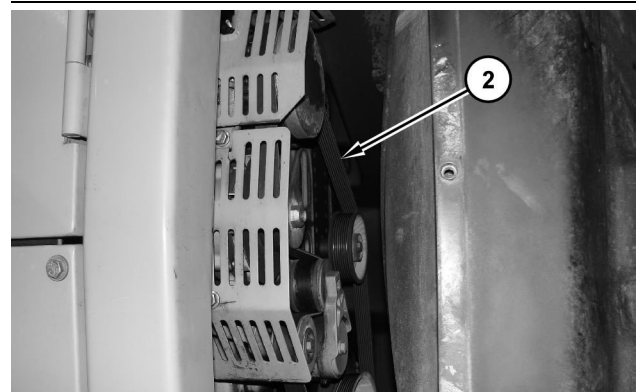

Illustration 90

g01368716

4. Install belt (2). Refer to Operation and Maintenance Manual, "Belt - Replace".

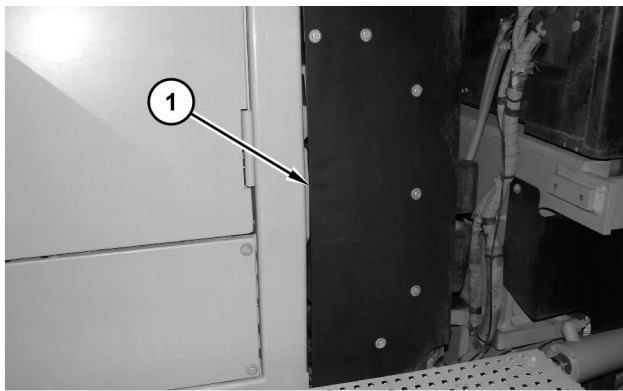

Illustration 91

g01368713

5. Install panel (1).
6. Charge the air conditioner system. Refer to Service Manual, SENR5664, "Air Conditioning and Heating Systems with R-134a Refrigerant" for the correct procedure. Refer to Dealer Service Tool Catalog, NENG2500, "Air Conditioning Tools" for the correct tools.

i03155340

Refrigerant Condenser - Remove

SMCS Code: 1805-011

Removal Procedure

Table 4

Required Tools			
Tool	Part Number	Part Description	Qty
A	138-7575	Link Bracket	2
B	312-8796	Handling Assembly ⁽¹⁾	1

⁽¹⁾ CE Compliant

NOTICE

Care must be taken to ensure that fluids are contained during performance of inspection, maintenance, testing, adjusting, and repair of the product. Be prepared to collect the fluid with suitable containers before opening any compartment or disassembling any component containing fluids.

Refer to Special Publication, NENG2500, "Dealer Service Tool Catalog" for tools and supplies suitable to collect and contain fluids on Cat® products.

Dispose of all fluids according to local regulations and mandates.

NOTICE

Keep all parts clean from contaminants.

Contaminants may cause rapid wear and shortened component life.

Note: Put identification marks on all lines, on all hoses, on all wires, and on all tubes for installation purposes. Plug all lines, hoses, and tubes. This helps to prevent fluid loss and this helps to keep contaminants from entering the system.

1. Connect the steering frame lock. Refer to Operation and Maintenance Manual, "Steering Frame Lock".

WARNING

Personal injury can result from contact with refrigerant.

Contact with refrigerant can cause frost bite. Keep face and hands away to help prevent injury.

Protective goggles must always be worn when refrigerant lines are opened, even if the gauges indicate the system is empty of refrigerant.

Always use precaution when a fitting is removed. Slowly loosen the fitting. If the system is still under pressure, release it slowly in a well ventilated area.

Personal injury or death can result from inhaling refrigerant through a lit cigarette.

Inhaling air conditioner refrigerant gas through a lit cigarette or other smoking method or inhaling fumes released from a flame contacting air conditioner refrigerant gas, can cause bodily harm or death.

Do not smoke when servicing air conditioners or wherever refrigerant gas may be present.

Use a certified recovery and recycling cart to properly remove the refrigerant from the air conditioning system.

2. Recover the air conditioner refrigerant from the air conditioner system. Refer to Service Manual, SENR5664, "Air Conditioning and Heating Systems with R-134a Refrigerant" for the procedure. Refer to Dealer Service Tool Catalog, NENG2500, "Air Conditioning Tools" for the correct tools.



Illustration 92 g01375545

3. Remove cover (1).

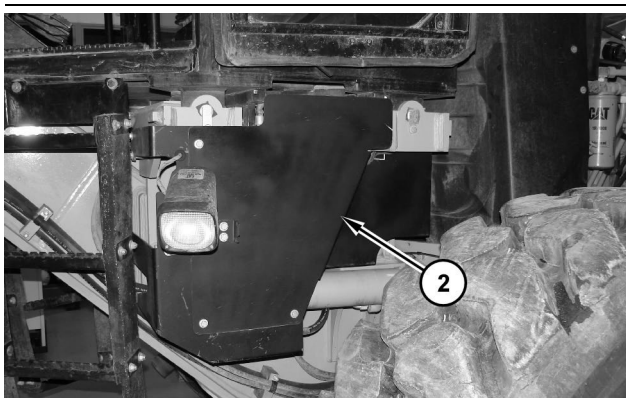

Illustration 93 g01375557

4. Remove cover (2).

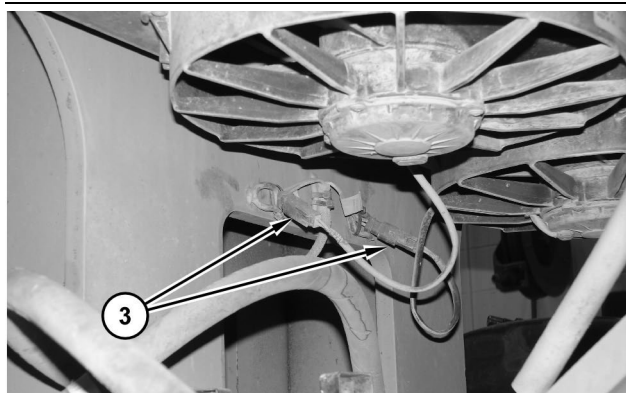

Illustration 94 g01375566

5. Disconnect harness assemblies (3).

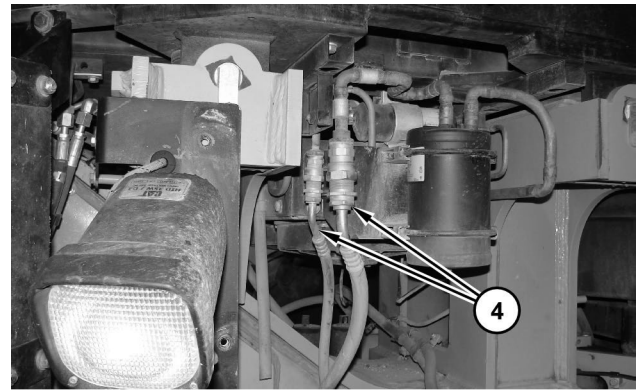

Illustration 95 g01375568

6. Disconnect hose assemblies (4).

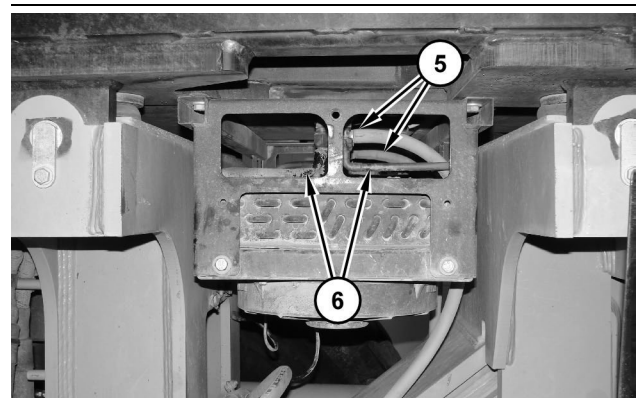

Illustration 96 g01375570

7. Disconnect hoses (5). Disconnect tube assemblies (6).

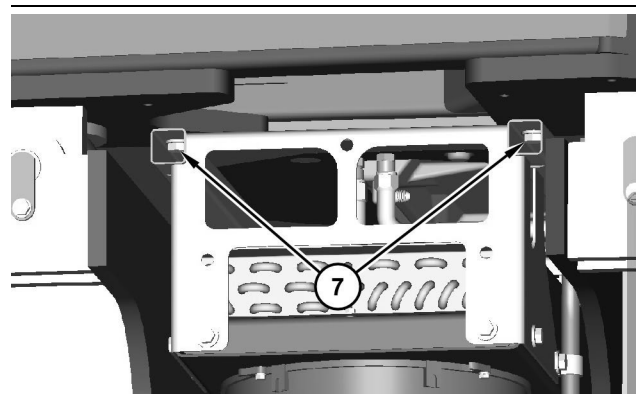

Illustration 97 g01375595

8. Remove bolts (7).

Disassembly and Assembly Section

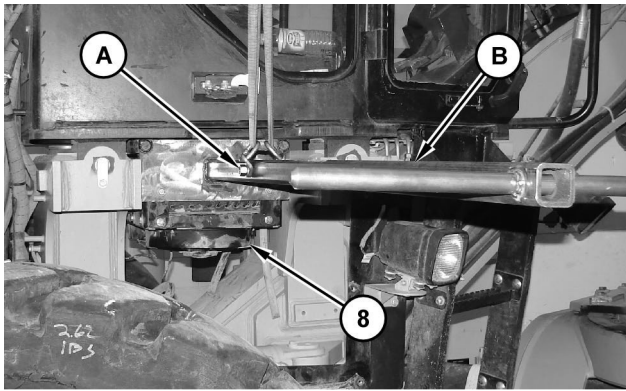

Illustration 98

g01375588

9. Install Tooling (A), Tooling (B), and a suitable lifting device onto refrigerant condenser (8). The weight of refrigerant condenser (8) is approximately 52 kg (115 lb).

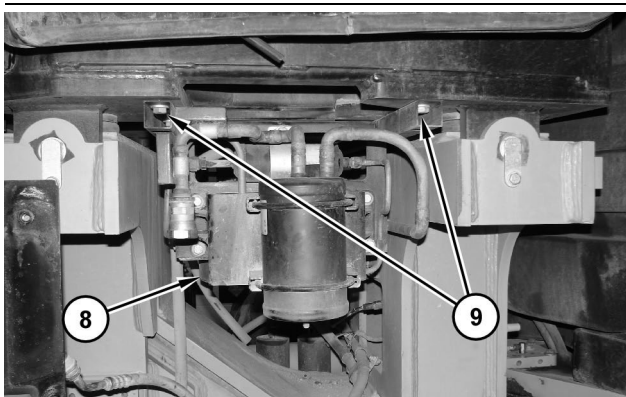

Illustration 99

g01375597

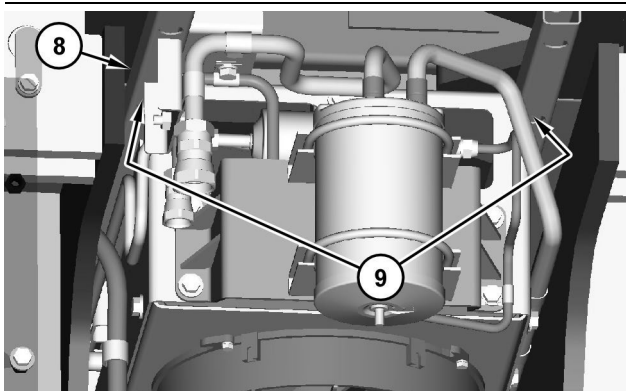

Illustration 100

g01375649

10. Remove bolts (9) in order to remove refrigerant condenser (8).

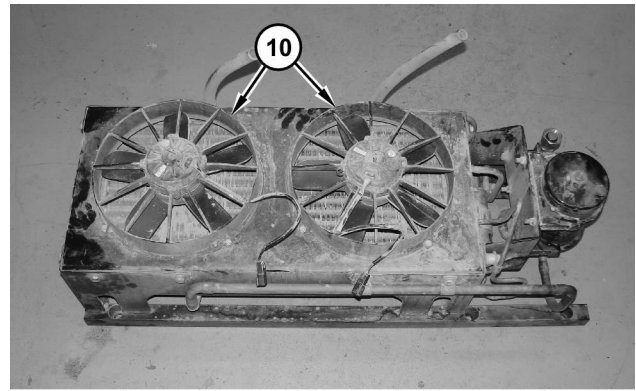

Illustration 101

g01376103

11. Remove fans (10).

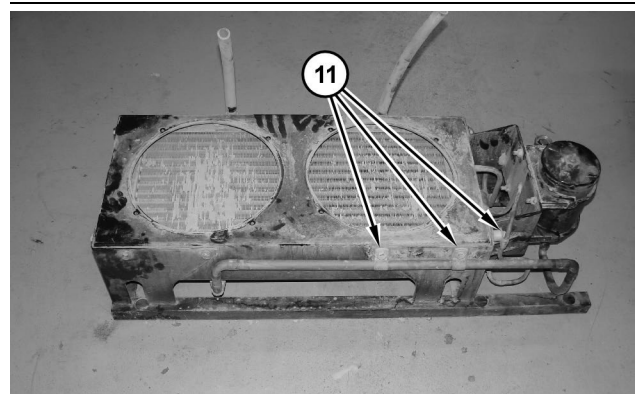

Illustration 102

g01376154

12. Remove clips (11).

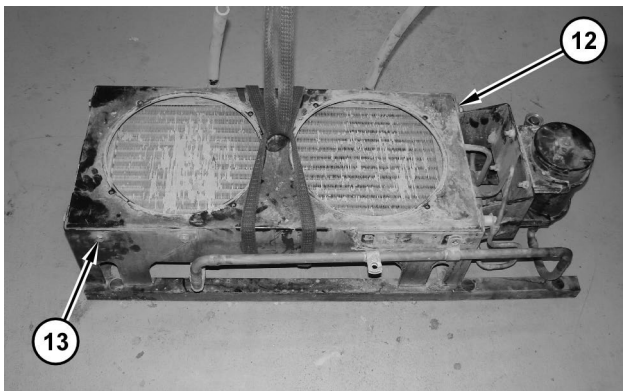

Illustration 103

g01376109

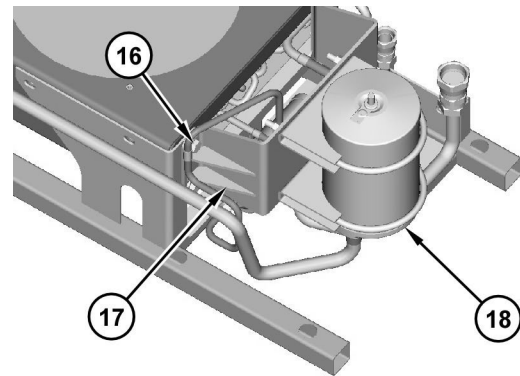

Illustration 106

g01376181

15. Remove bolts (16). Position bracket assembly (17) and accumulator (18) out of the way.

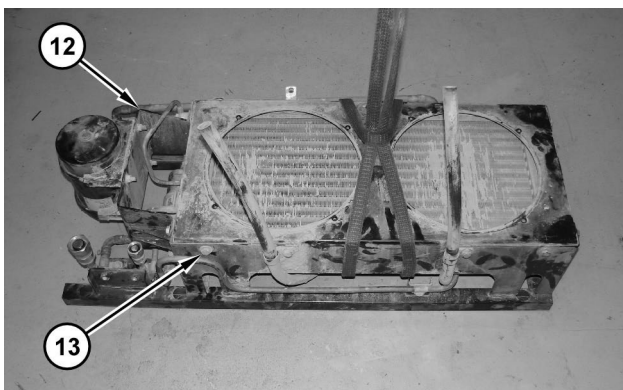

Illustration 104

g01376114

13. Use a suitable lifting device in order to support coil assembly (12). Remove bolts (13).

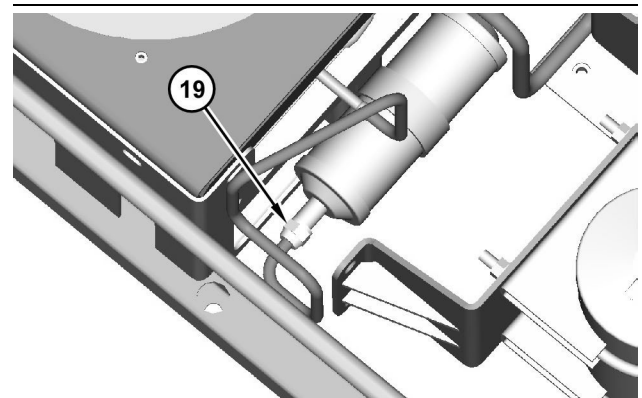

Illustration 107

g01376188

16. Disconnect tube assembly (19).

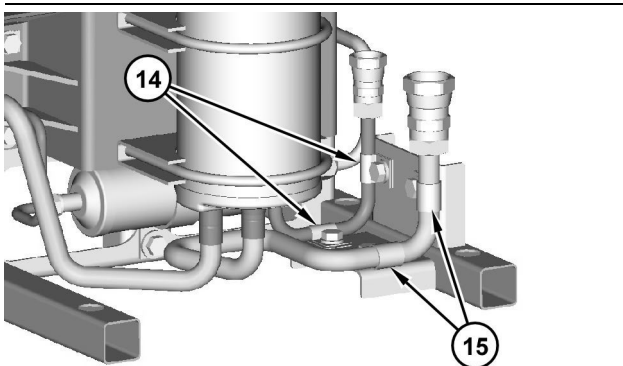

Illustration 105

g01376162

14. Remove clips (14) and clips (15).

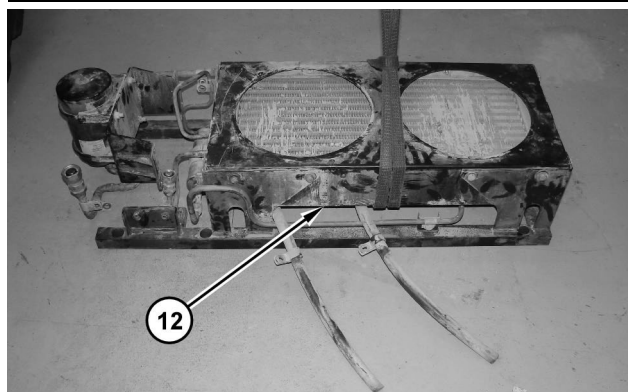

Illustration 108

g01376195

17. Remove coil assembly (12).

i02808593

Refrigerant Condenser - Install

SMCS Code: 1805-012

Installation Procedure

Table 5

Required Tools			
Tool	Part Number	Part Description	Qty
A	138-7575	Link Bracket	2
B	312-8796	Handling Assembly	1

NOTICE

Keep all parts clean from contaminants.

Contaminants may cause rapid wear and shortened component life.

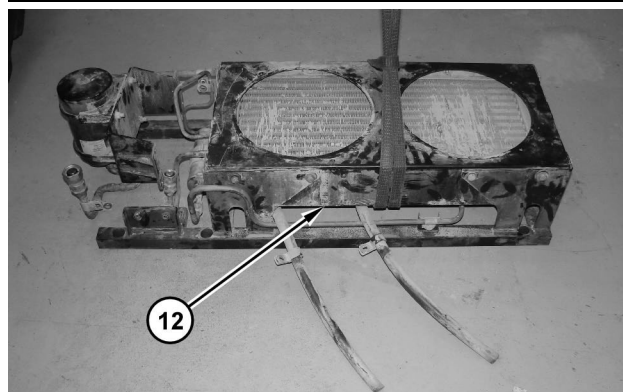

Illustration 109

g01376195

1. Use a suitable lifting device in order to install coil assembly (12). Use the suitable lifting device in order to support coil assembly (12).

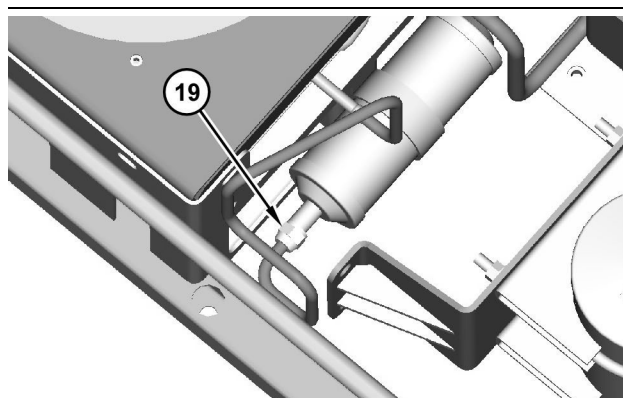

Illustration 110

g01376188

2. Connect tube assembly (19).

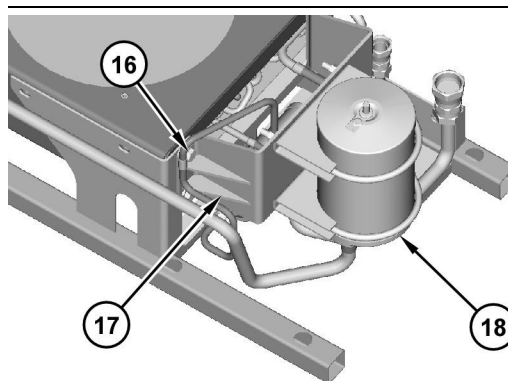

Illustration 111

g01376181

3. Position bracket assembly (17) and accumulator (18). Install bolts (16).

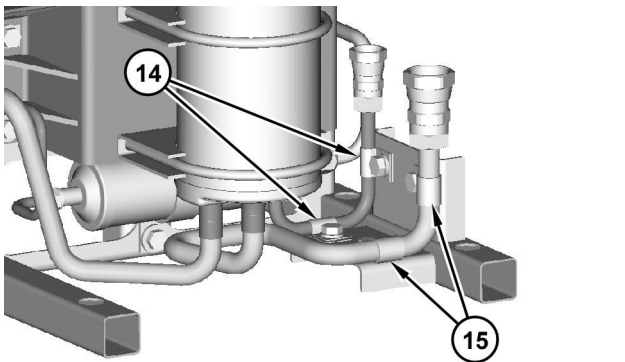

Illustration 112 g01376162

4. Install clips (15) and clips (14).

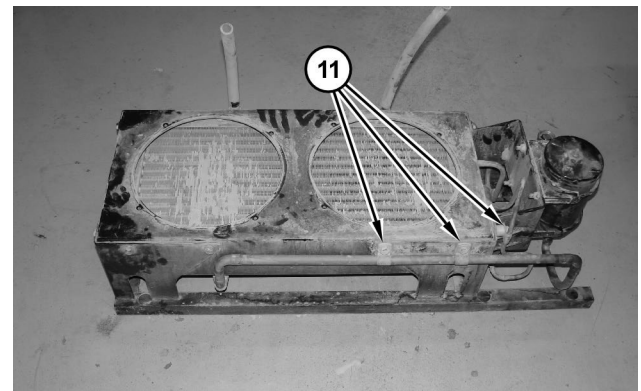

Illustration 115 g01376154

6. Install clips (11).

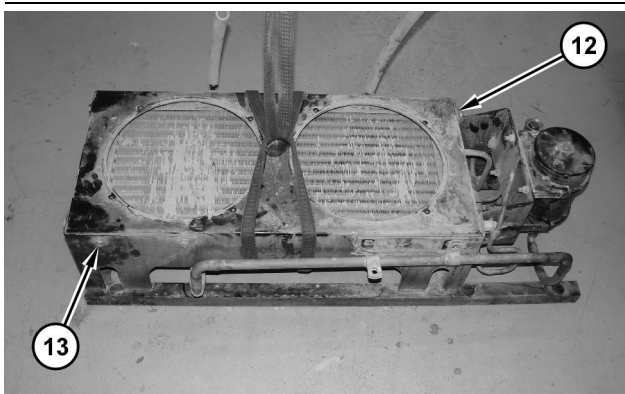

Illustration 113 g01376109

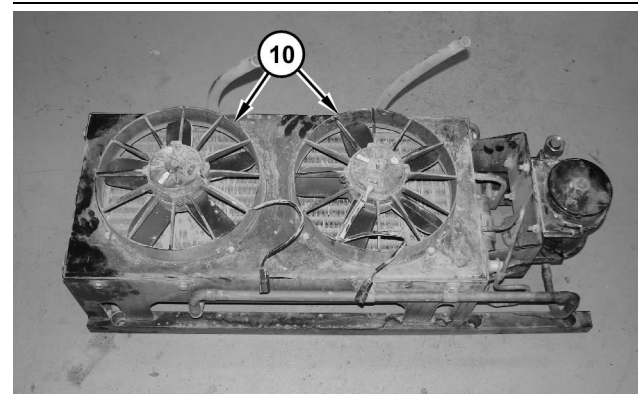

Illustration 116 g01376103

7. Install fans (10).

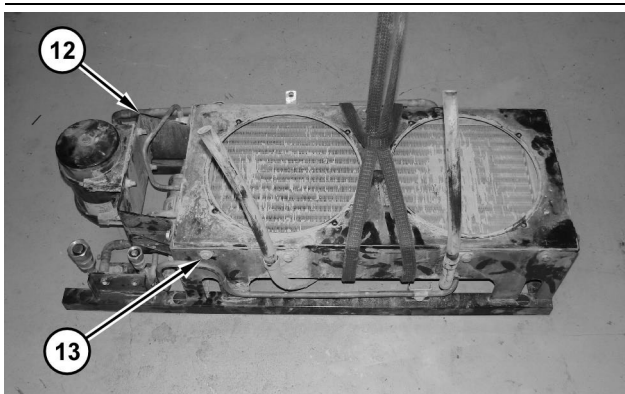

Illustration 114 g01376114

5. Install bolts (13). Remove the suitable lifting device from coil assembly (12).

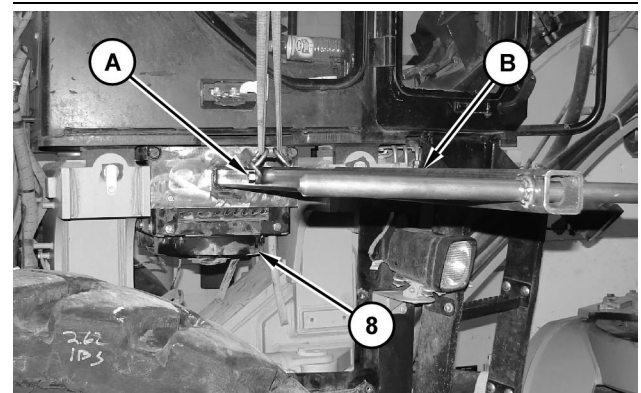

Illustration 117 g01375588

8. Use Tooling (A), Tooling (B), and a suitable lifting device in order to position refrigerant condenser (8). The weight of refrigerant condenser (8) is approximately 52 kg (115 lb).

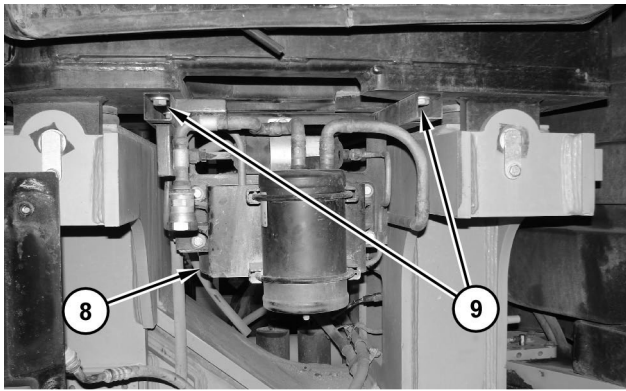

Illustration 118

g01375597

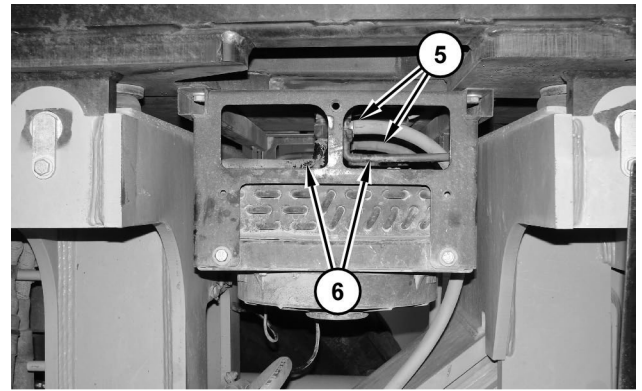

Illustration 121

g01375570

11. Connect tube assemblies (6). Connect hoses (5).

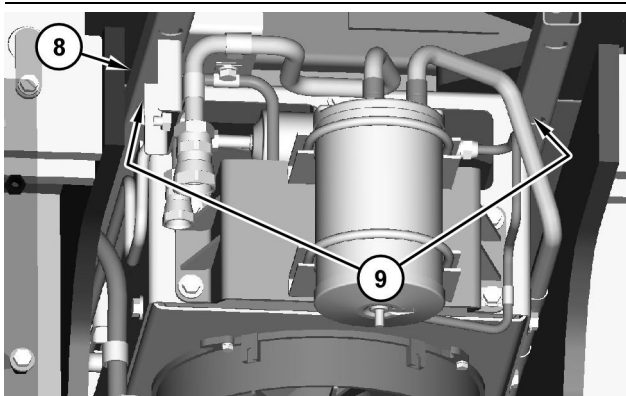

Illustration 119

g01375649

9. Install bolts (9) in order to install refrigerant condenser (8).



Illustration 122

g01375568

12. Connect hose assemblies (4).

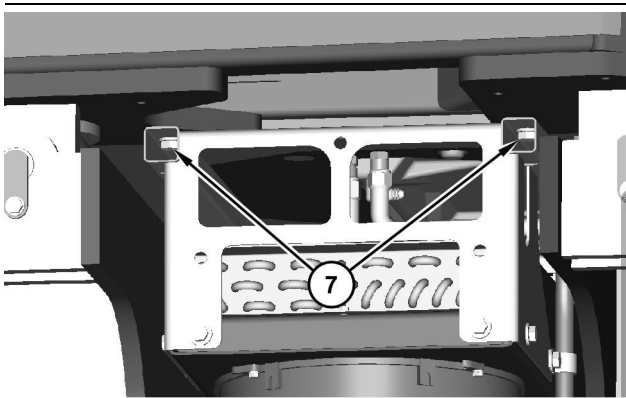

Illustration 120

g01375595

10. Install bolts (7).

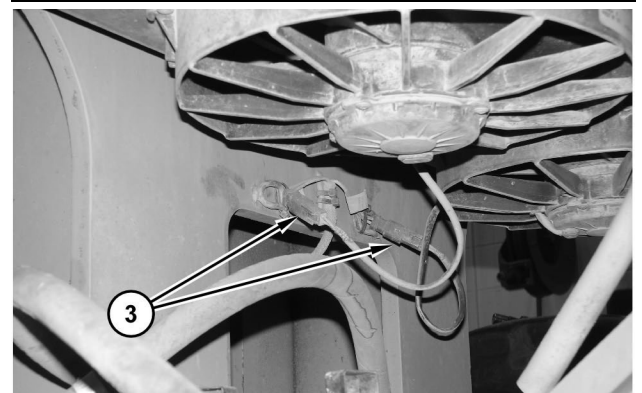

Illustration 123

g01375566

13. Connect harness assemblies (3).

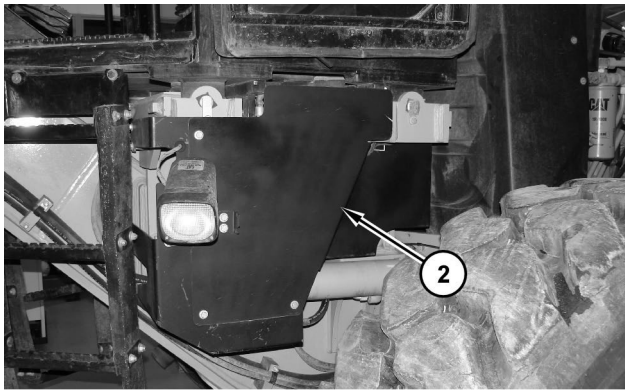

Illustration 124

g01375557

14. Install cover (2).



Illustration 125

g01375545

15. Install cover (1).

16. Charge the air conditioner system. Refer to Service Manual, SENR5664, "Air Conditioning and Heating Systems with R-134a Refrigerant" for the procedure. Refer to Dealer Service Tool Catalog, NENG2500, "Air Conditioning Tools" for the correct tools.

17. Separate the steering frame lock. Refer to Operation and Maintenance Manual, "Steering Frame Lock - Separate and Connect".

i02777616

Fuel Transfer Pump - Remove and Install

SMCS Code: 1256-010

Removal Procedure

WARNING

Fuel leaked or spilled onto hot surfaces or electrical components can cause a fire. To help prevent possible injury, turn the start switch off when changing fuel filters or water separator elements. Clean up fuel spills immediately.

NOTICE

Care must be taken to ensure that fluids are contained during performance of inspection, maintenance, testing, adjusting, and repair of the product. Be prepared to collect the fluid with suitable containers before opening any compartment or disassembling any component containing fluids.

Refer to Special Publication, NENG2500, "Dealer Service Tool Catalog" for tools and supplies suitable to collect and contain fluids on Cat® products.

Dispose of all fluids according to local regulations and mandates.

NOTICE

Keep all parts clean from contaminants.

Contaminants may cause rapid wear and shortened component life.

Note: Put identification marks on all lines, on all hoses, on all wires, and on all tubes for installation purposes. Plug all lines, hoses, and tubes. This helps to prevent fluid loss and this helps to keep contaminants from entering the system.

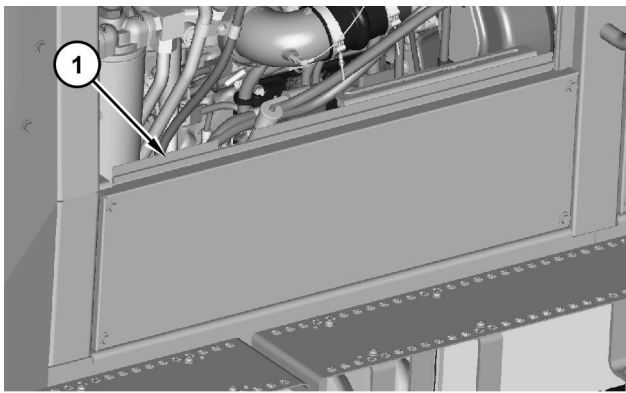

Illustration 126

g01387827

1. Remove panel (1).

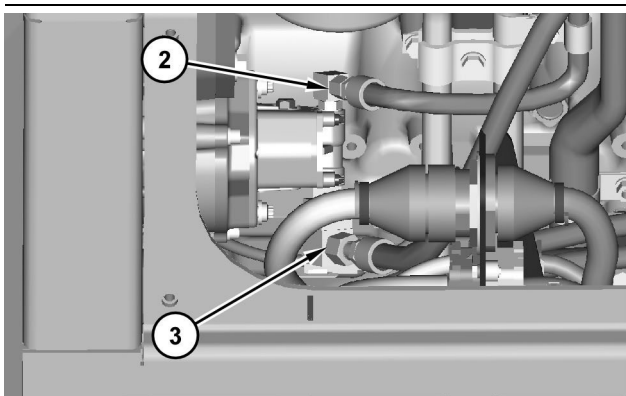

Illustration 127

g01387813

2. Disconnect hose assembly (2). Disconnect hose assembly (3).

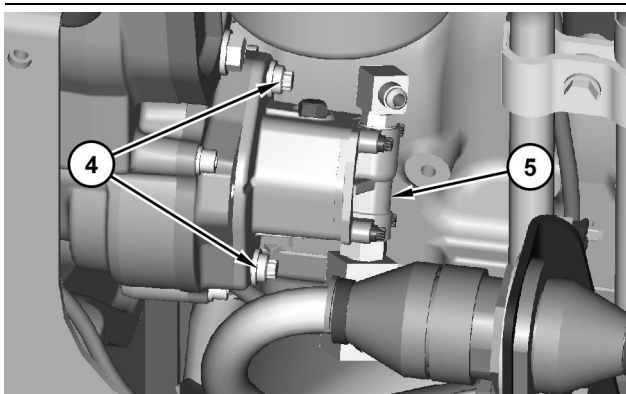

Illustration 128

g01387817

3. Remove bolts (4). Remove fuel transfer pump (5).

Installation Procedure

NOTICE

Care must be taken to ensure that fluids are contained during performance of inspection, maintenance, testing, adjusting, and repair of the product. Be prepared to collect the fluid with suitable containers before opening any compartment or disassembling any component containing fluids.

Refer to Special Publication, NENG2500, "Dealer Service Tool Catalog" for tools and supplies suitable to collect and contain fluids on Cat® products.

Dispose of all fluids according to local regulations and mandates.

NOTICE

Keep all parts clean from contaminants.

Contaminants may cause rapid wear and shortened component life.

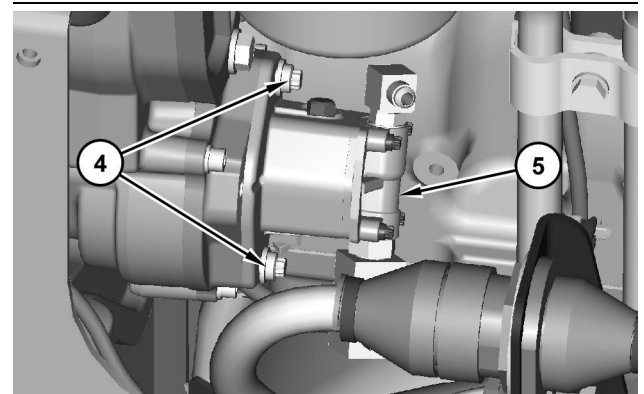

Illustration 129

g01387817

1. Install fuel transfer pump (5). Install bolts (4).

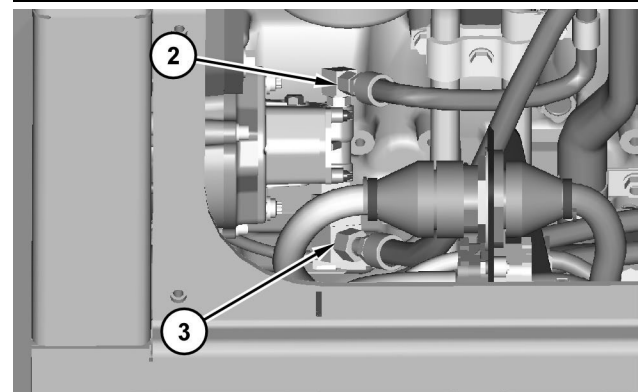

Illustration 130

g01387813

2. Connect hose assembly (3). Connect hose assembly (2).

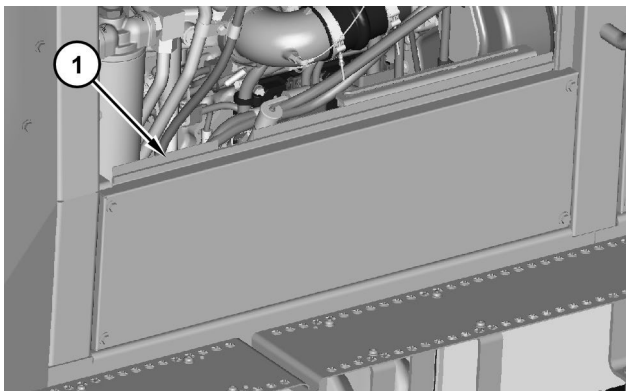

Illustration 131

g01387827

3. Install panel (1).
4. Prime the fuel system. Refer to Operation and Maintenance Manual, "Fuel System - Prime".

i02764652

Engine Oil Filter Base - Remove

SMCS Code: 1306-011

Removal Procedure

NOTICE

Keep all parts clean from contaminants.

Contaminants may cause rapid wear and shortened component life.

NOTICE

Care must be taken to ensure that fluids are contained during performance of inspection, maintenance, testing, adjusting, and repair of the product. Be prepared to collect the fluid with suitable containers before opening any compartment or disassembling any component containing fluids.

Refer to Special Publication, NENG2500, "Dealer Service Tool Catalog" for tools and supplies suitable to collect and contain fluids on Cat® products.

Dispose of all fluids according to local regulations and mandates.

Note: Put identification marks on all lines, on all hoses, on all wires, and on all tubes for installation purposes. Plug all lines, hoses, and tubes. This helps to prevent fluid loss and this helps to keep contaminants from entering the system.

1. Drain the engine oil into a suitable container for storage or disposal. Refer to Operation and Maintenance Manual, "Engine Oil and Filter - Change".
2. Drain the engine coolant into a suitable container for storage or disposal. Refer to Operation and Maintenance Manual, "Cooling System Coolant (ELC) - Change".

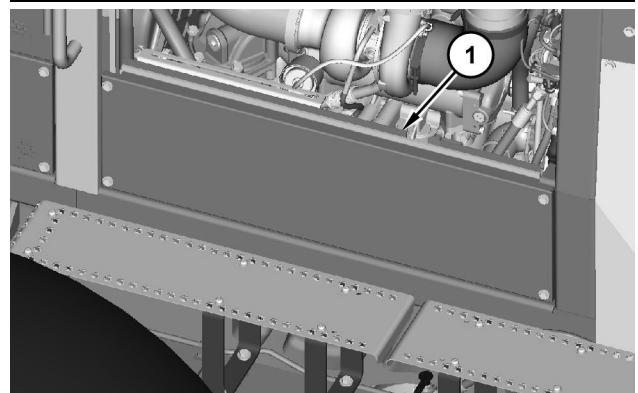

Illustration 132

g01383936

3. Remove panel (1).

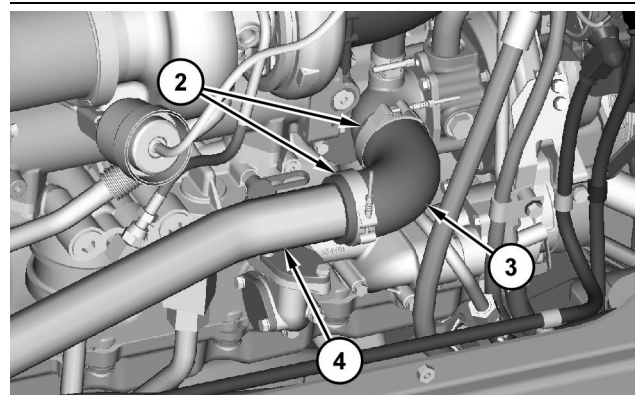

Illustration 133

g01383941

4. Disconnect clamps (2). Remove hose (3).

Disassembly and Assembly Section

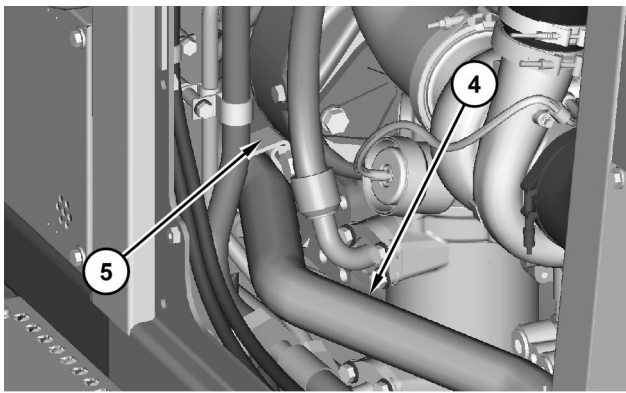

Illustration 134

g01383946

5. Remove clip (5). Position tube (4) out of the way.

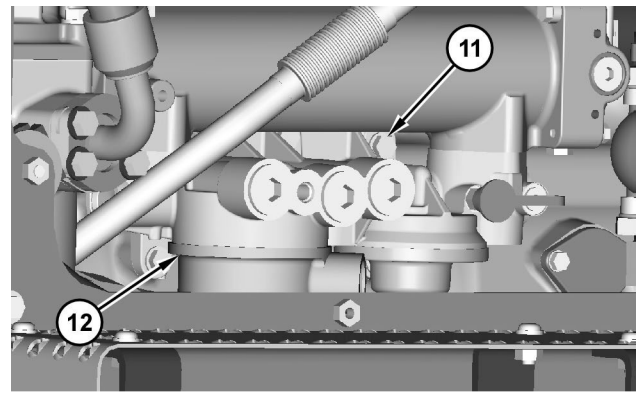

Illustration 137

g01383967

9. Remove bolts (11). Remove engine oil filter base (12).

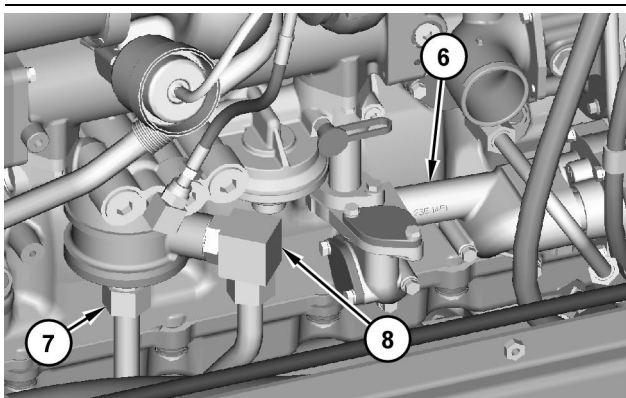

Illustration 135

g01383955

6. Remove oil pump (6). Refer to Disassembly and Assembly, "Engine Oil Pump - Remove".

7. Disconnect tube assembly (7). Disconnect fitting (8).

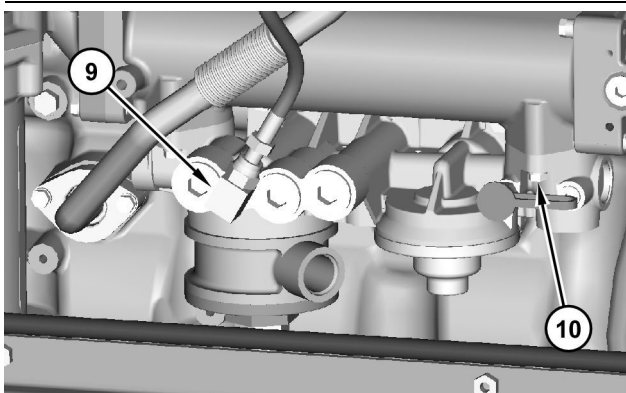

Illustration 136

g01383959

8. Disconnect fitting (9). Remove bolts (10).

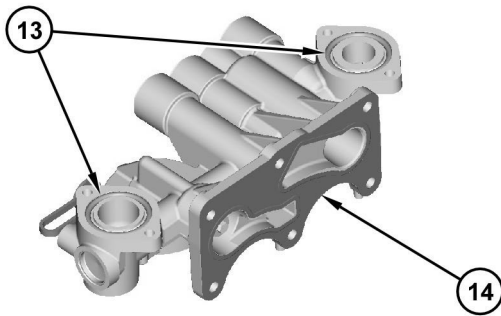

Illustration 138

g01383984

10. Remove O-ring seals (13). Remove gasket (14).

i02642398

Engine Oil Filter Base - Disassemble

SMCS Code: 1306-015

Disassembly Procedure

Start By:

- a. Remove the engine oil filter base. Refer to Disassembly and Assembly, "Engine Oil Filter Base - Remove".

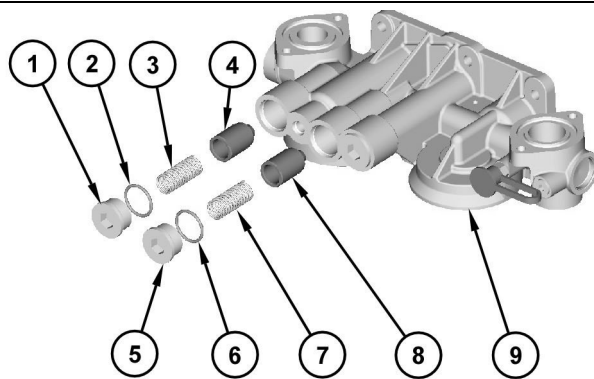

Illustration 139

g01325673

⚠ WARNING

Personal injury can result from being struck by parts propelled by a released spring force.

Make sure to wear all necessary protective equipment.

Follow the recommended procedure and use all recommended tooling to release the spring force.

1. Remove plug (1), O-ring seal (2), spring (3), and plunger (4) from oil filter base (9).
2. Remove plug (5), O-ring seal (6), spring (7), and plunger (8) from oil filter base (9).

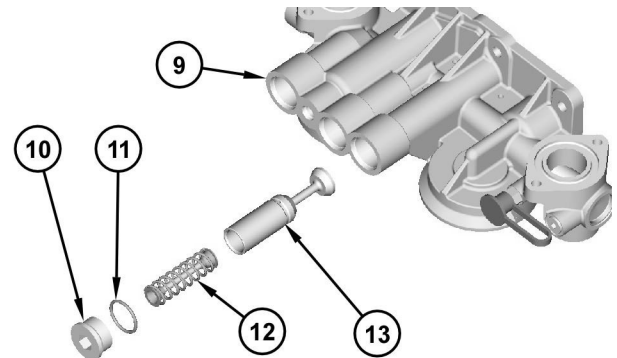

Illustration 140

g01325679

⚠ WARNING

Personal injury can result from being struck by parts propelled by a released spring force.

Make sure to wear all necessary protective equipment.

Follow the recommended procedure and use all recommended tooling to release the spring force.

3. Remove plug (10), O-ring seal (11), spring assembly (12), and valve (13) from oil filter housing (9).

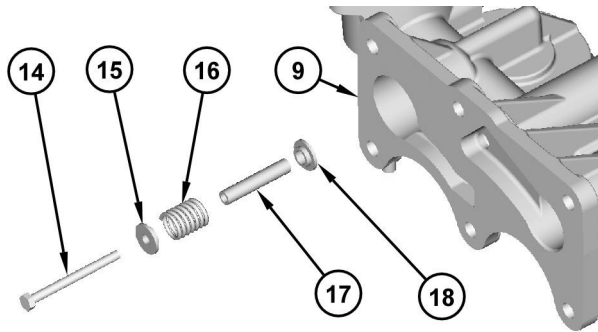

Illustration 141

g01325682

⚠ WARNING

Personal injury can result from being struck by parts propelled by a released spring force.

Make sure to wear all necessary protective equipment.

Follow the recommended procedure and use all recommended tooling to release the spring force.

4. Remove bolt (14), seat (15), spring (16), spacer (17), and retainer (18) from oil filter base (9).

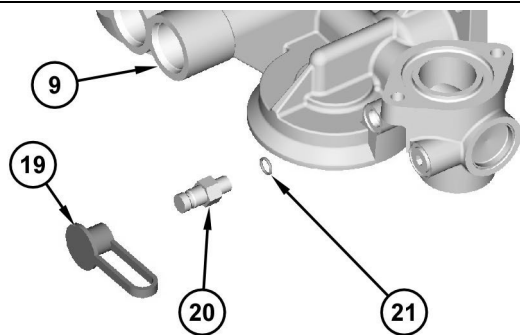

Illustration 142

g01325684

5. Remove dust cap (19), test port (20), and O-ring seal (21) from oil filter base (9).

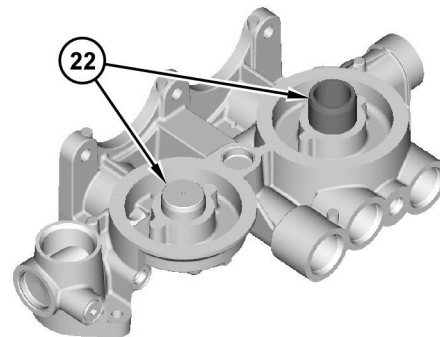

Illustration 143

g01325685

6. If necessary, remove studs (22).

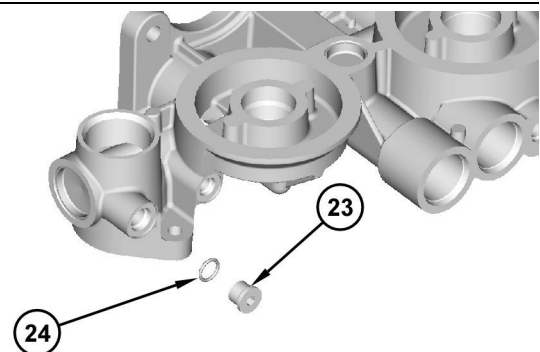

Illustration 144

g01325687

7. Remove plug (23) and O-ring seal (24).

i02642399

Engine Oil Filter Base - Assemble

SMCS Code: 1306-016

Assembly Procedure

NOTICE

Care must be taken to ensure that fluids are contained during performance of inspection, maintenance, testing, adjusting, and repair of the product. Be prepared to collect the fluid with suitable containers before opening any compartment or disassembling any component containing fluids.

Refer to Special Publication, NENG2500, "Dealer Service Tool Catalog" for tools and supplies suitable to collect and contain fluids on Cat® products.

Dispose of all fluids according to local regulations and mandates.

1. Inspect the O-ring seals. Replace the O-ring seals that are worn or damaged.

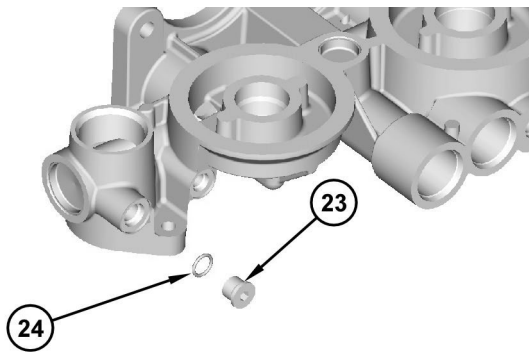

Illustration 145

g01325687

2. Install plug (23) and O-ring seal (24). Tighten plug (23) to a torque of $100 \pm 15 \text{ N}\cdot\text{m}$ ($74 \pm 11 \text{ lb ft}$).

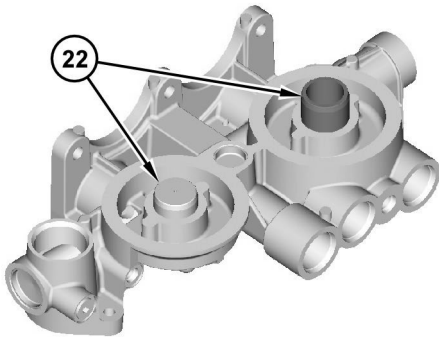

Illustration 146

g01325685

3. If the studs were removed, install studs (22). Tighten studs (22) to a torque of $68 \pm 7 \text{ N}\cdot\text{m}$ ($50 \pm 5 \text{ lb ft}$).

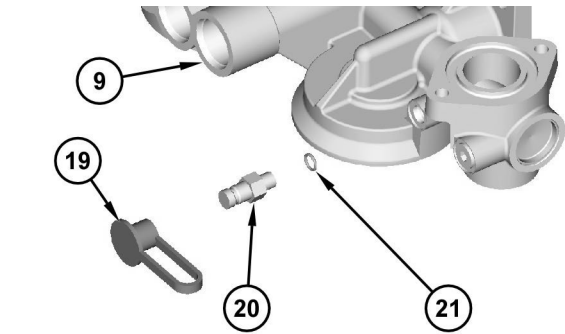

Illustration 147

g01325684

4. Install O-ring seal (21), test port (20), and dust cap (19) from oil filter base (9).

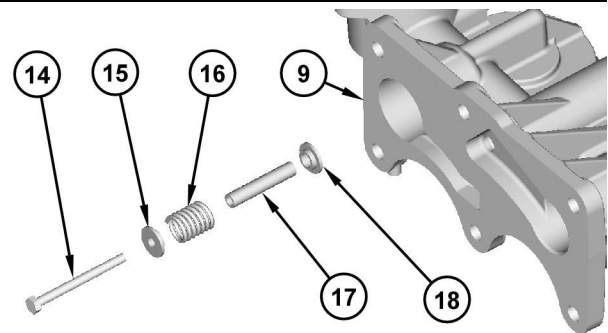

Illustration 148

g01325682

WARNING

Improper assembly of parts that are spring loaded can cause bodily injury.

To prevent possible injury, follow the established assembly procedure and wear protective equipment.

5. Install retainer (18), spacer (17), spring (16), seat (15), and bolt (14) from oil filter base (9).

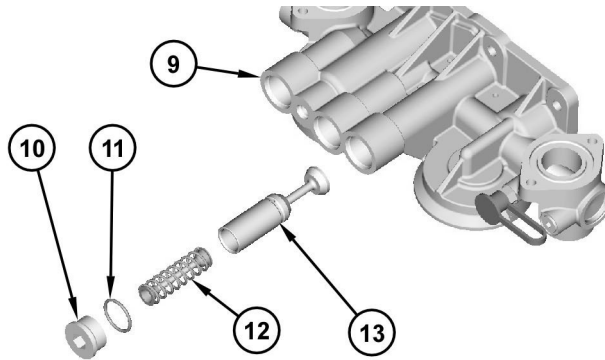

Illustration 149

g01325679

⚠ WARNING

Improper assembly of parts that are spring loaded can cause bodily injury.

To prevent possible injury, follow the established assembly procedure and wear protective equipment.

6. Install valve (13), spring assembly (12), O-ring seal (11), and plug (10) from oil filter housing (9). Tighten plug (10) to a torque $100 \pm 15 \text{ N}\cdot\text{m}$ ($74 \pm 11 \text{ lb ft}$).

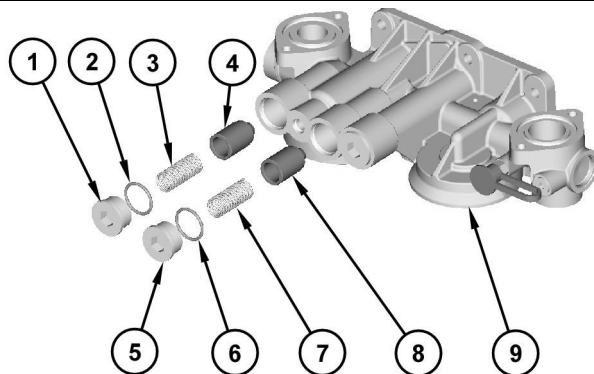

Illustration 150

g01325673

⚠ WARNING

Improper assembly of parts that are spring loaded can cause bodily injury.

To prevent possible injury, follow the established assembly procedure and wear protective equipment.

7. Install plunger (8), spring (7), O-ring seal (6), and plug (5) onto oil filter base (9). Tighten plug (5) to a torque $100 \pm 15 \text{ N}\cdot\text{m}$ ($74 \pm 11 \text{ lb ft}$).

8. Install plunger (4), spring (3), O-ring seal (2), and plug (1) onto oil filter base (9). Tighten plug (1) to a torque $100 \pm 15 \text{ N}\cdot\text{m}$ ($74 \pm 11 \text{ lb ft}$).

End By:

- a. Install the engine oil filter base. Refer to Disassembly and Assembly, "Engine Oil Filter Base - Install".

i02764654

Engine Oil Filter Base - Install

SMCS Code: 1306-012

Installation Procedure

NOTICE

Keep all parts clean from contaminants.

Contaminants may cause rapid wear and shortened component life.

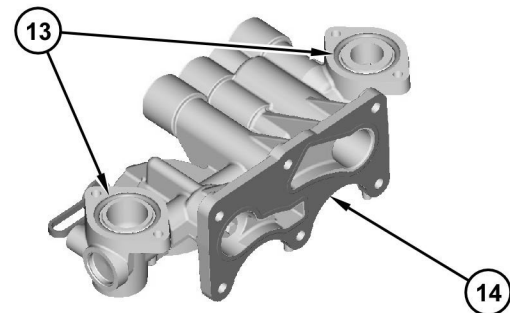

Illustration 151

g01383984

1. Install gasket (14). Install O-ring seals (13).

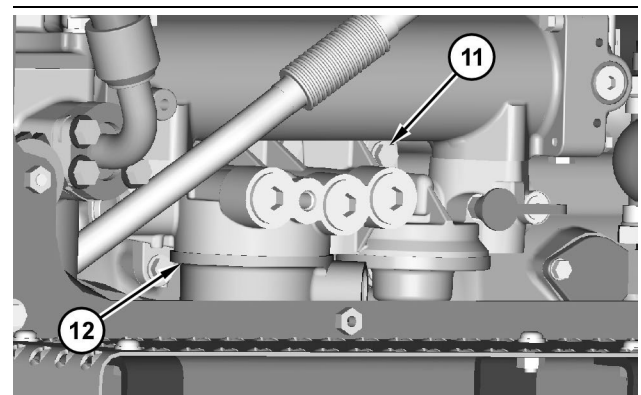

Illustration 152

g01383967

2. Install engine oil filter base (12). Install bolts (11).

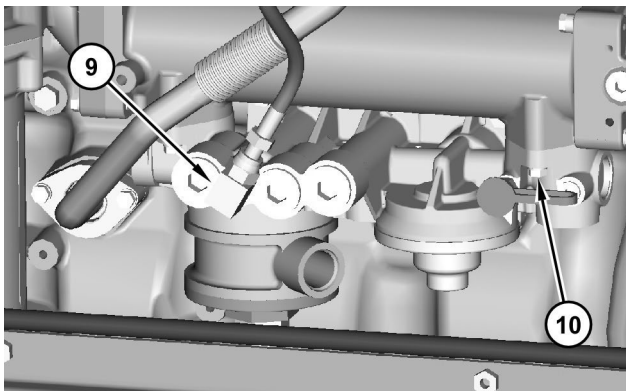

Illustration 153

g01383959

3. Install bolts (10). Connect fitting (9).

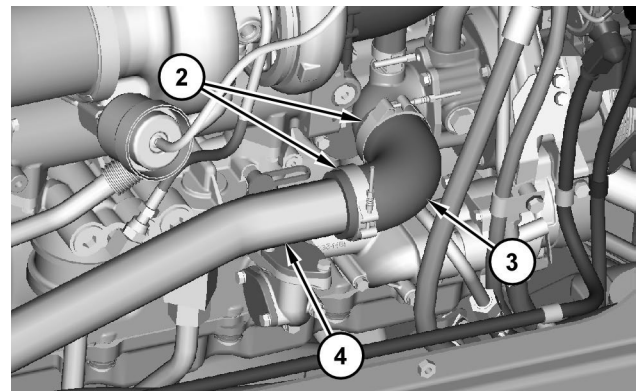

Illustration 156

g01383941

7. Install hose (3). Connect clamps (2).

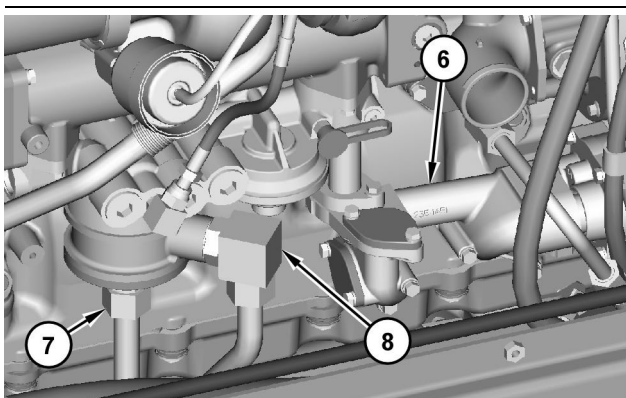

Illustration 154

g01383955

4. Connect fitting (8). Connect tube assembly (7).

5. Install oil pump (6). Refer to Disassembly and Assembly, "Engine Oil Pump - Install".

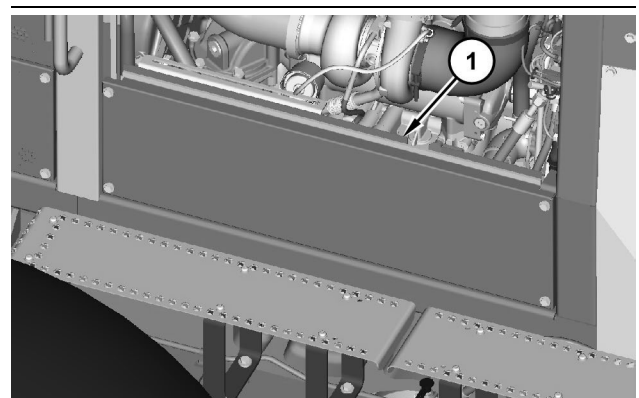

Illustration 157

g01383936

8. Install panel (1).

9. Refill the engine coolant. Refer to Operation and Maintenance Manual, "Capacities - Refill".

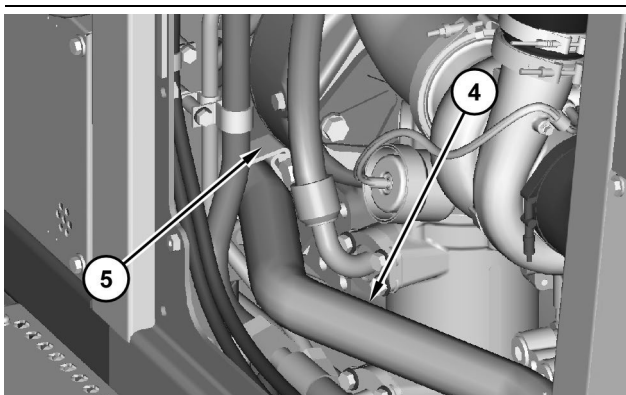

Illustration 155

g01383946

6. Position tube (4) and install clip (5).

10. Refill the engine oil. Refer to Operation and Maintenance Manual, "Capacities - Refill".

i02765158

Engine Oil Cooler - Remove and Install

SMCS Code: 1378-010

Removal Procedure

Start By:

- a. Remove the engine oil filter base. Refer to Disassembly and Assembly, "Engine Oil Filter Base - Remove".

NOTICE

Keep all parts clean from contaminants.

Contaminants may cause rapid wear and shortened component life.

NOTICE

Care must be taken to ensure that fluids are contained during performance of inspection, maintenance, testing, adjusting, and repair of the product. Be prepared to collect the fluid with suitable containers before opening any compartment or disassembling any component containing fluids.

Refer to Special Publication, NENG2500, "Dealer Service Tool Catalog" for tools and supplies suitable to collect and contain fluids on Cat® products.

Dispose of all fluids according to local regulations and mandates.

Note: Put identification marks on all lines, on all hoses, on all wires, and on all tubes for installation purposes. Plug all lines, hoses, and tubes. This helps to prevent fluid loss and this helps to keep contaminants from entering the system.

1. Inspect the O-ring seals. Replace the O-ring seals that are worn or damaged.

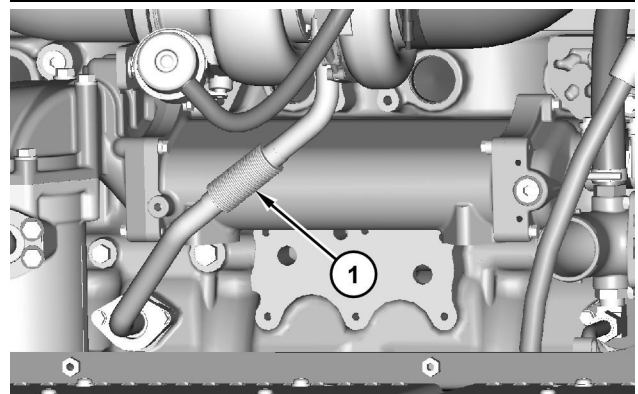

Illustration 158

g01384066

2. Remove tube assembly (1).

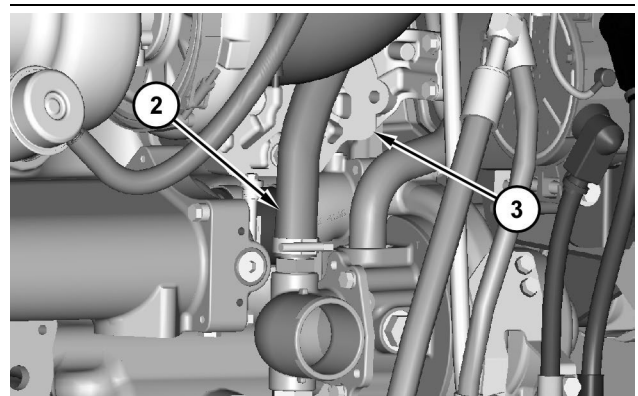

Illustration 159

g01384074

3. Disconnect hose (2). Remove bracket (3).

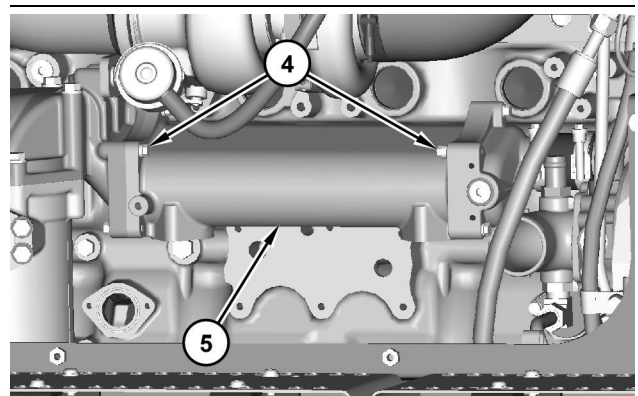

Illustration 160

g01384081

4. Remove bolts (4). Remove engine oil cooler (5).

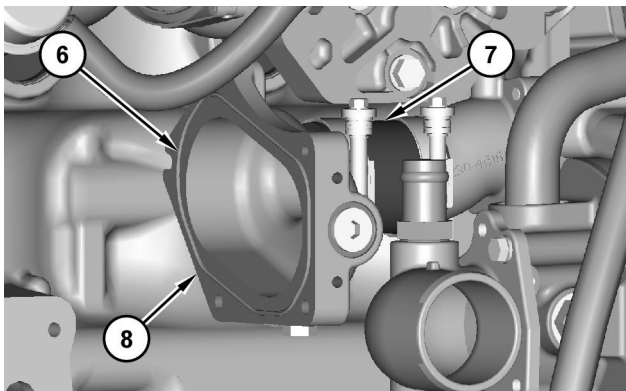

Illustration 161

g01384085

5. Remove O-ring seal (6). Disconnect hose (7). Remove bonnet (8).

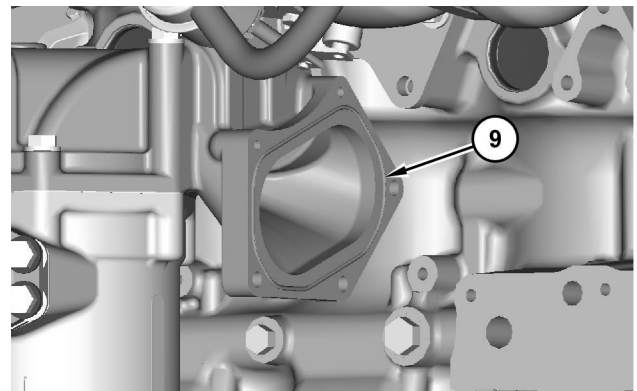

Illustration 163

g01384086

1. Install O-ring seal (9).

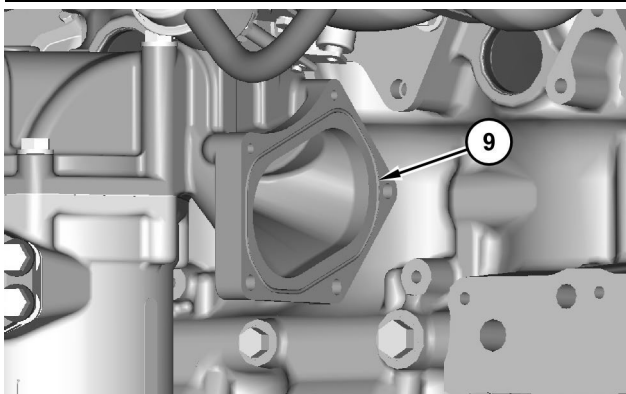

Illustration 162

g01384086

6. Remove O-ring seal (9).

Installation Procedure

NOTICE

Keep all parts clean from contaminants.

Contaminants may cause rapid wear and shortened component life.

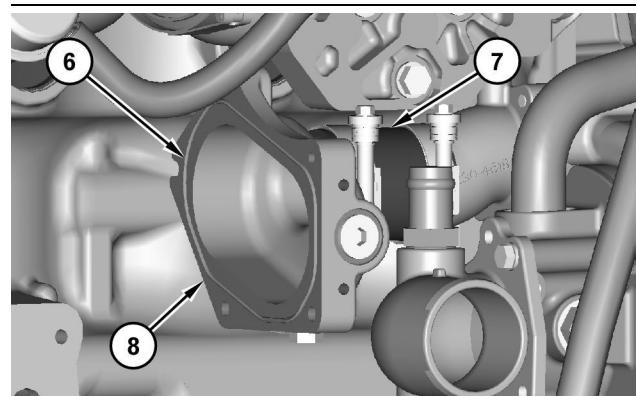

Illustration 164

g01384085

2. Install bonnet (8). Connect hose (7). Install O-ring seal (6).

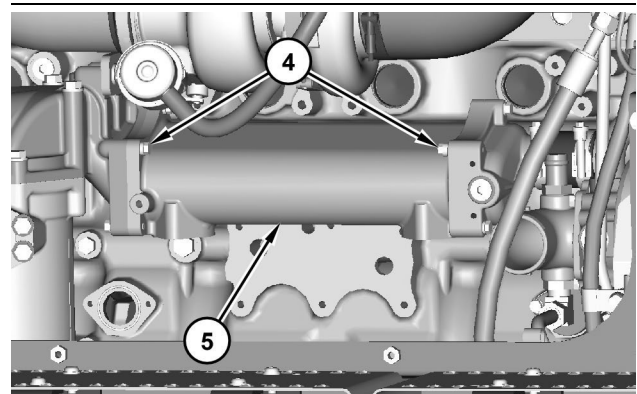

Illustration 165

g01384081

3. Install engine oil cooler (5). Install bolts (4).

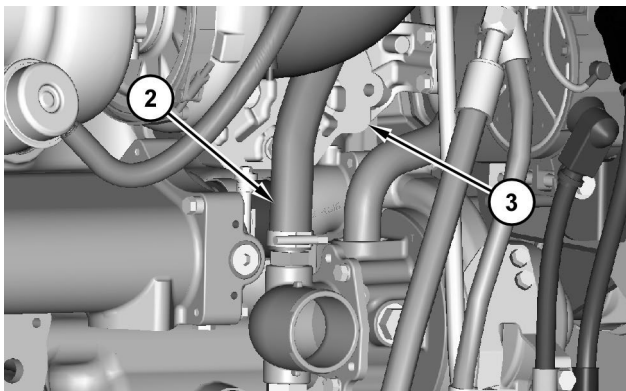

Illustration 166

g01384074

4. Install bracket (3). Connect hose (2).

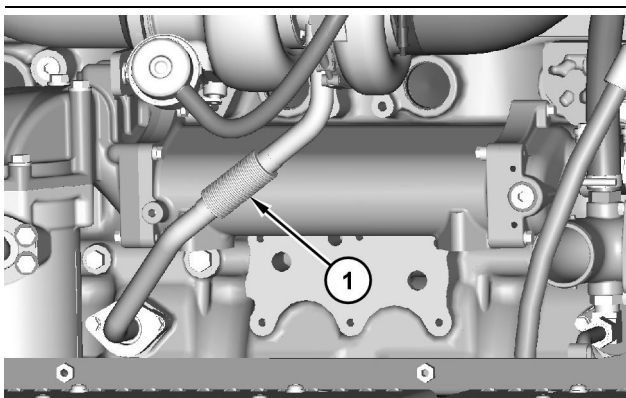

Illustration 167

g01384066

5. Install tube assembly (1).

End By:

a. Install the engine oil filter base. Refer to Disassembly and Assembly, "Engine Oil Filter Base - Install".

i02729642

Fuel Priming Pump and Water Separator - Remove and Install

SMCS Code: 1258-010; 1263-010

Removal Procedure

Table 6

Required Tools			
Tool	Part Number	Part Description	Qty
A	185-3630	Strap Wrench As	1

NOTICE

Keep all parts clean from contaminants.

Contaminants may cause rapid wear and shortened component life.

NOTICE

Care must be taken to ensure that fluids are contained during performance of inspection, maintenance, testing, adjusting, and repair of the product. Be prepared to collect the fluid with suitable containers before opening any compartment or disassembling any component containing fluids.

Refer to Special Publication, NENG2500, "Dealer Service Tool Catalog" for tools and supplies suitable to collect and contain fluids on Cat® products.

Dispose of all fluids according to local regulations and mandates.

Note: Put identification marks on all lines, on all hoses, on all wires, and on all tubes for installation purposes. Plug all lines, hoses, and tubes. This helps to prevent fluid loss and this helps to keep contaminants from entering the system.

1. Drain the fuel filter into a suitable container for storage or disposal.

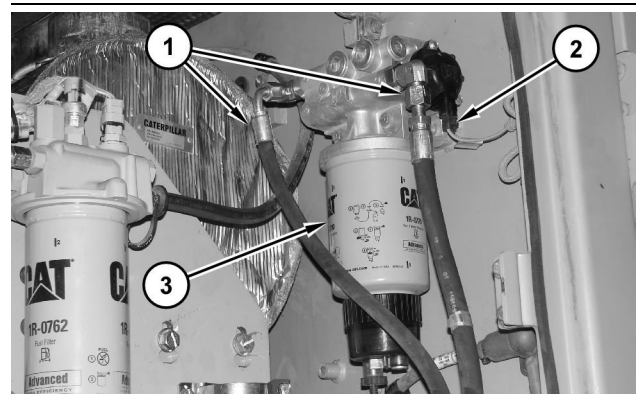

Illustration 168

g01368936

2. Disconnect hose assemblies (1). Disconnect harness assembly (2). Use Tooling (A) in order to remove fuel filter (3). Refer to Operation and Maintenance Manual, "Fuel System Primary Filter - Clean/Inspect/Replace".

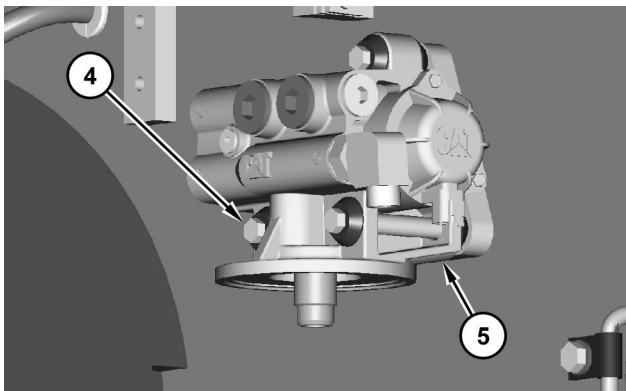

Illustration 169

g01368940

3. Remove bolts (4) in order to remove filter base (5).

Installation Procedure

Table 7

Required Tools			
Tool	Part Number	Part Description	Qty
A	185-3630	Strap Wrench As	1

NOTICE

Keep all parts clean from contaminants.

Contaminants may cause rapid wear and shortened component life.

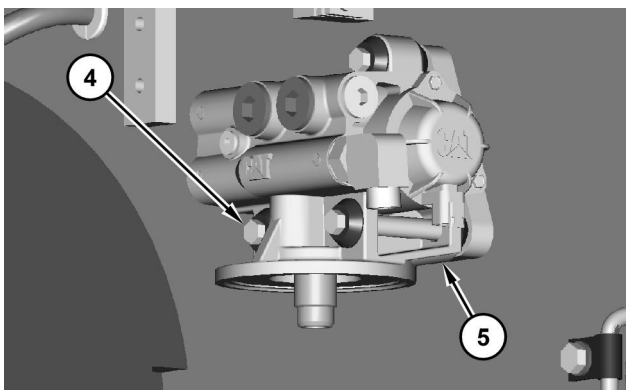

Illustration 170

g01368940

1. Position filter base (5) and install bolts (4).

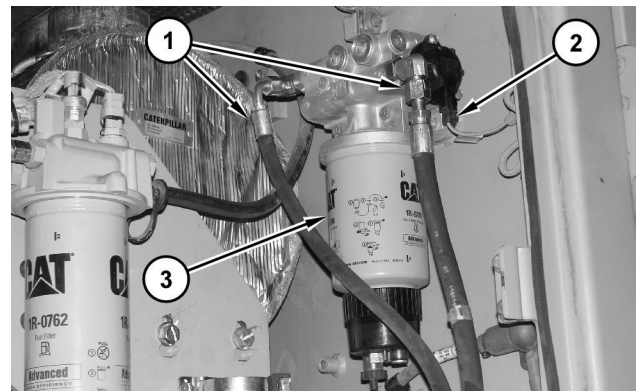

Illustration 171

g01368936

2. Use Tooling (A) in order to install fuel filter (3). Refer to Operation and Maintenance Manual, "Fuel System Primary Filter - Clean/Inspect/Replace". Connect harness assembly (2). Connect hose assemblies (1).

i02648881

Water Pump - Remove

SMCS Code: 1361-011

Removal Procedure

Note: Put identification marks on all lines, on all hoses, on all wires, and on all tubes for installation purposes. Plug all lines, hoses, and tubes. This helps to prevent fluid loss and this helps to keep contaminants from entering the system.

NOTICE

Keep all parts clean from contaminants.

Contaminants may cause rapid wear and shortened component life.

NOTICE

Care must be taken to ensure that fluids are contained during performance of inspection, maintenance, testing, adjusting, and repair of the product. Be prepared to collect the fluid with suitable containers before opening any compartment or disassembling any component containing fluids.

Refer to Special Publication, NENG2500, "Dealer Service Tool Catalog" for tools and supplies suitable to collect and contain fluids on Cat® products.

Dispose of all fluids according to local regulations and mandates.

⚠ WARNING

At operating temperature, the engine coolant is hot and under pressure.

Steam can cause personal injury.

Check the coolant level only after the engine has been stopped and the fill cap is cool enough to touch with your bare hand.

Remove the fill cap slowly to relieve pressure.

Cooling system conditioner contains alkali. Avoid contact with the skin and eyes to prevent personal injury.

1. Drain the engine coolant into a suitable container for storage or disposal. Refer to Operation and Maintenance Manual, "Cooling System Extended Life Coolant - Change".

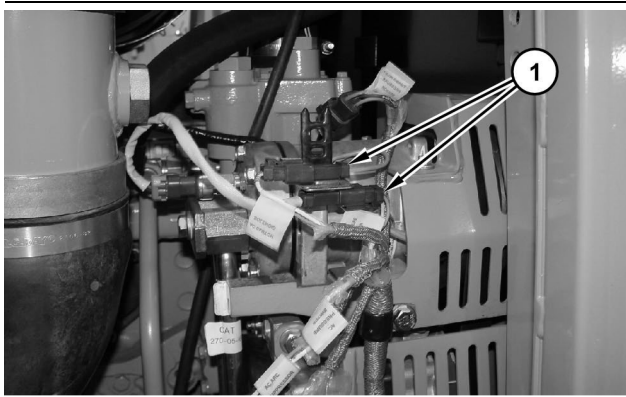

Illustration 172

g01329841

2. Disconnect harness assemblies (1).

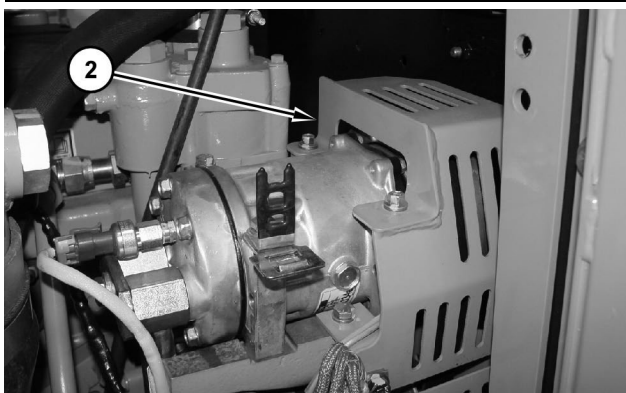

Illustration 173

g01329843

3. Remove guard (2).

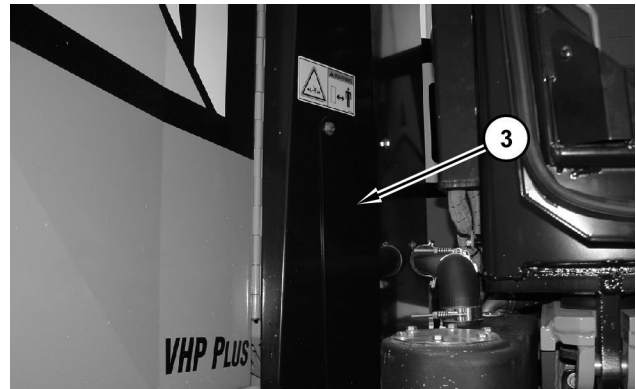

Illustration 174

g01329853

4. Remove panel (3).

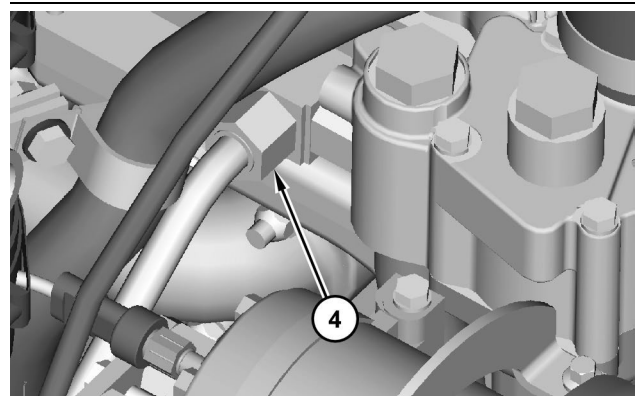

Illustration 175

g01329868

5. Disconnect tube assembly (4).

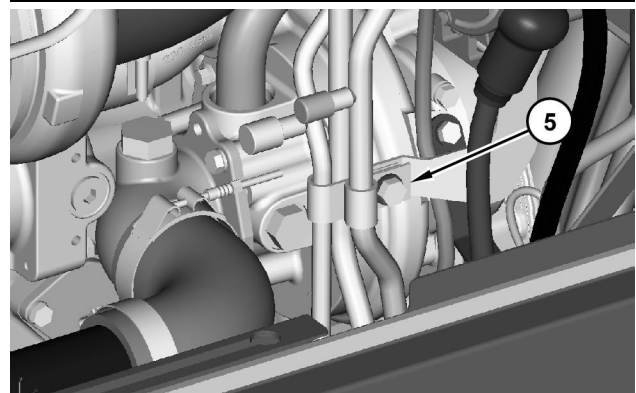

Illustration 176

g01329880

6. Remove clips (5).

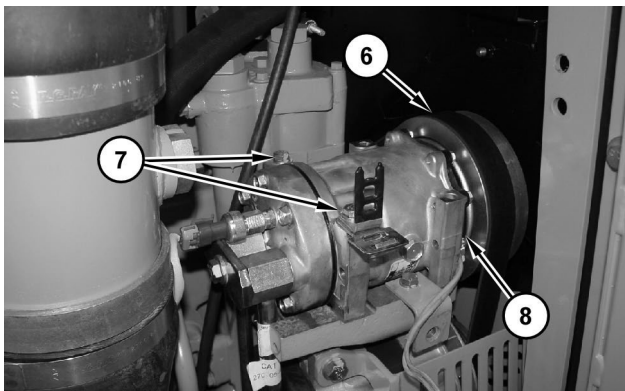

Illustration 177

g01329859

7. Remove belt (6). Remove bolts (7). Position refrigerant compressor (8) out of the way.

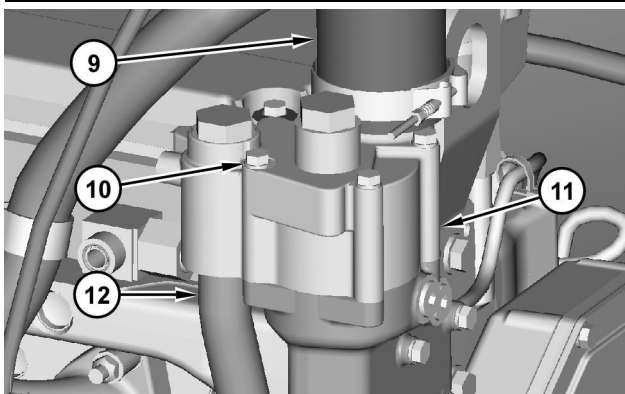

Illustration 178

g01329896

8. Disconnect hose (9). Remove bolts (10) in order to remove housing (11). Remove tube (12).

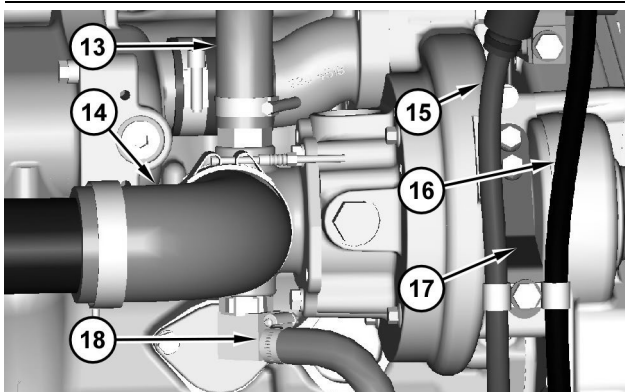

Illustration 179

g01329918

9. Disconnect hose (13). Disconnect hose (14).
10. Disconnect cable assembly (15) and cable assembly (16). Disconnect bracket (17).

11. Disconnect hose (18).

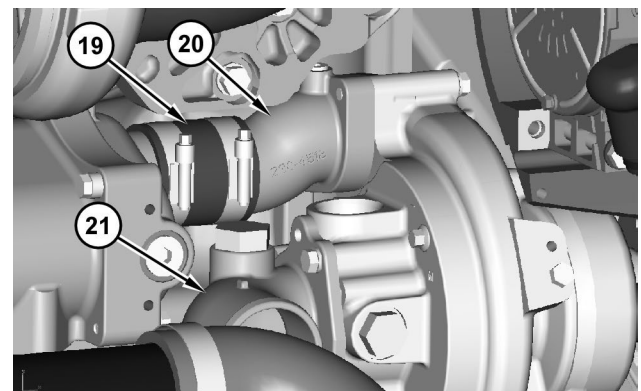

Illustration 180

g01329930

12. Disconnect hose (19). Remove elbow (20).
 Remove elbow (21).

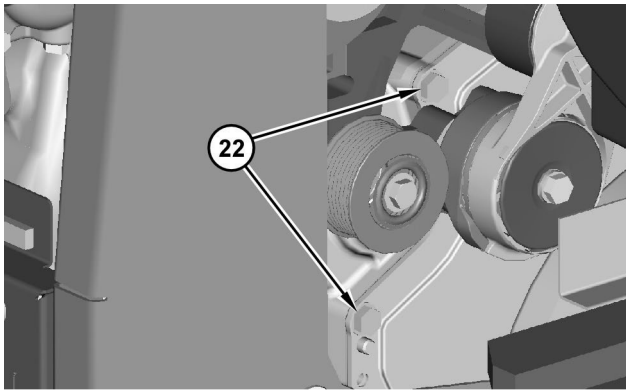

Illustration 181

g01329940

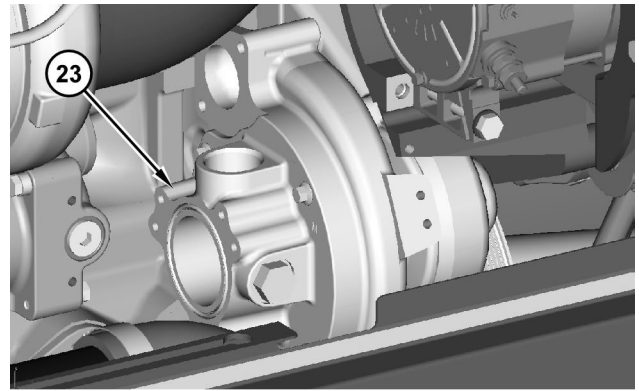

Illustration 183

g01329942

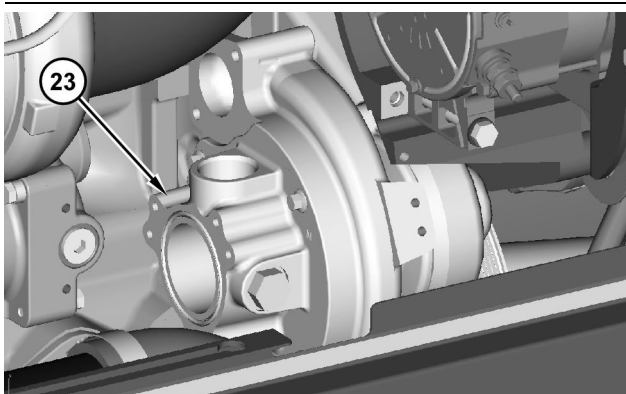

Illustration 182

g01329942

13. Remove bolts (22) in order to remove water pump (23).

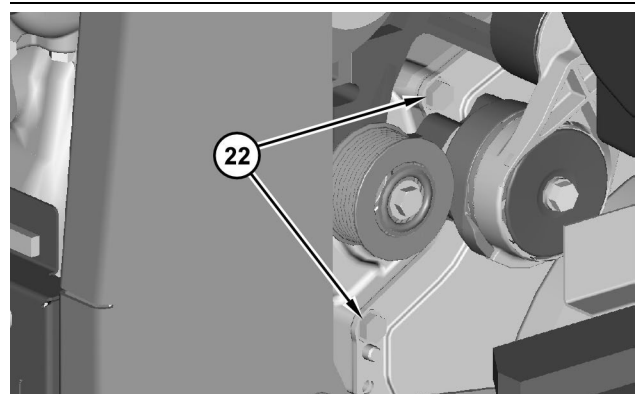

Illustration 184

g01329940

1. Install water pump (23). Install bolts (22).

i02648882

Water Pump - Install

SMCS Code: 1361-012

Installation Procedure

NOTICE

Keep all parts clean from contaminants.

Contaminants may cause rapid wear and shortened component life.

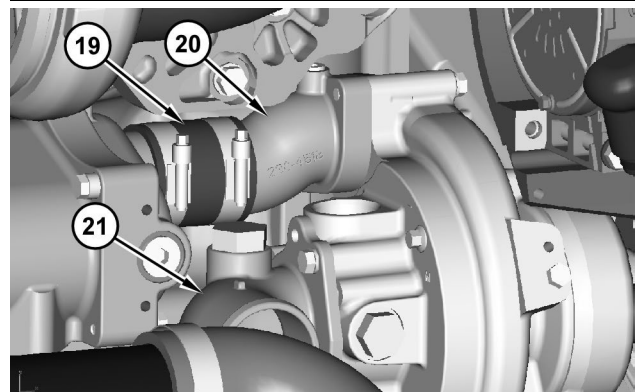

Illustration 185

g01329930

2. Install elbow (21). Install elbow (20). Connect hose (19).

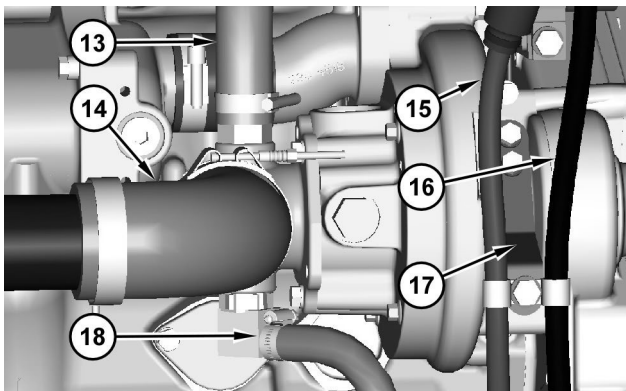

Illustration 186

g01329918

3. Connect hose (18).
4. Connect bracket (17). Connect cable assembly (16). Connect cable assembly (15).
5. Connect hose (14). Connect hose (13).

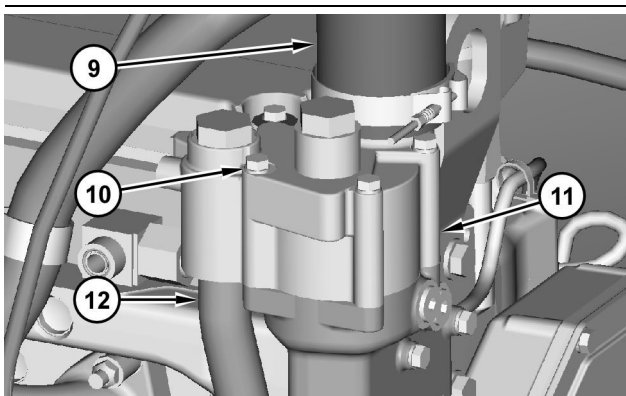

Illustration 187

g01329896

6. Install tube (12). Install housing (11). Install bolts (10). Connect hose (9).

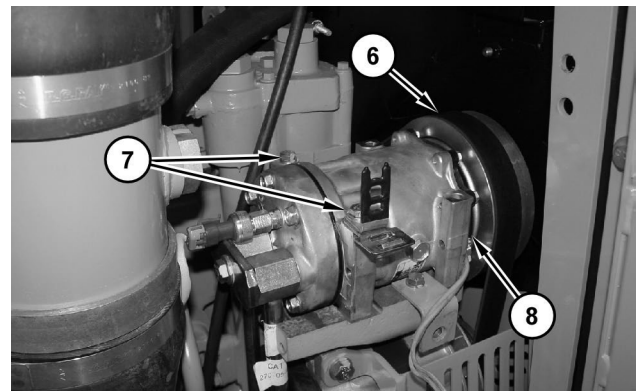

Illustration 188

g01329859

7. Position refrigerant compressor (8) and install bolts (7). Install belt (6).

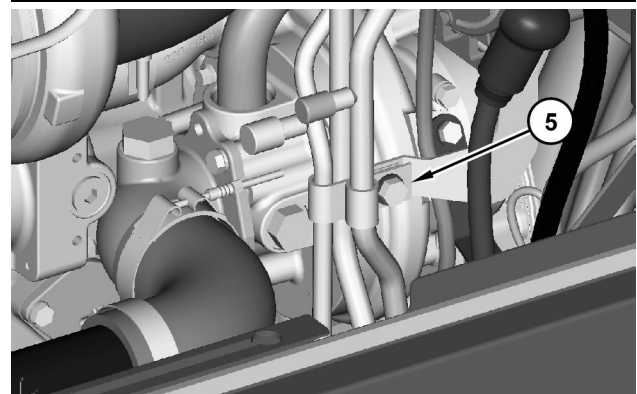

Illustration 189

g01329880

8. Install clips (5).

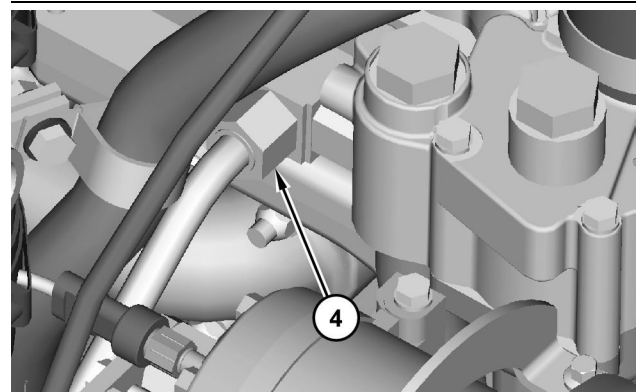

Illustration 190

g01329868

9. Connect tube assembly (4).

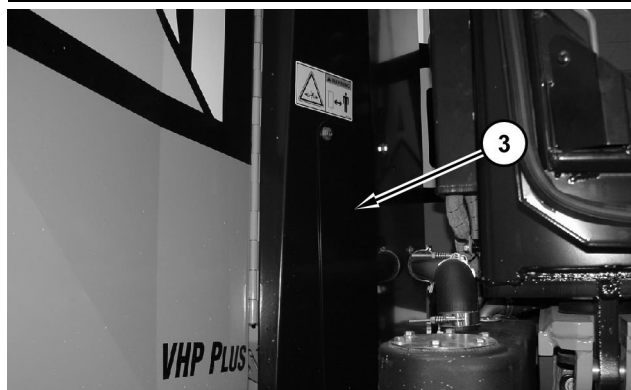

Illustration 191

g01329853

10. Install panel (3).

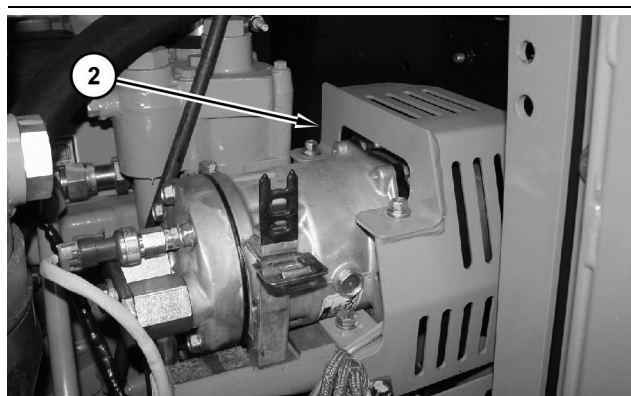

Illustration 192

g01329843

11. Install guard (2).

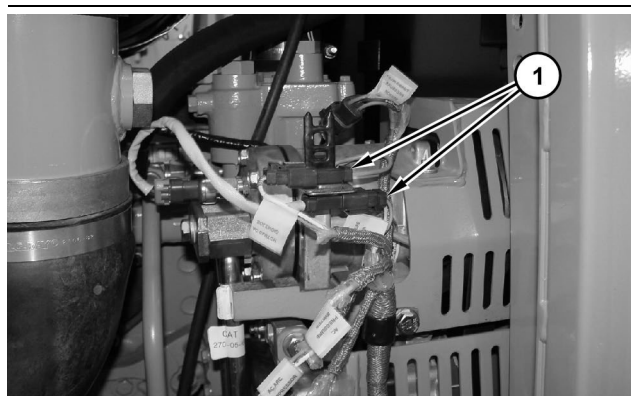

Illustration 193

g01329841

12. Connect harness assemblies (1).

13. Fill the engine coolant. Refer to Operation and Maintenance Manual, "Cooling System Extended Life Coolant - Change".

i02729430

Fuel Filter (Secondary) and Fuel Filter Base - Remove and Install

SMCS Code: 1261-010-SE; 1262-010-SE

Removal Procedure

Table 8

Required Tools			
Tool	Part Number	Part Description	Qty
A	185-3630	Strap Wrench As	1

NOTICE

Keep all parts clean from contaminants.

Contaminants may cause rapid wear and shortened component life.

Note: Put identification marks on all lines, on all hoses, on all wires, and on all tubes for installation purposes. Plug all lines, hoses, and tubes. This helps to prevent fluid loss and this helps to keep contaminants from entering the system.

NOTICE

Care must be taken to ensure that fluids are contained during performance of inspection, maintenance, testing, adjusting, and repair of the product. Be prepared to collect the fluid with suitable containers before opening any compartment or disassembling any component containing fluids.

Refer to Special Publication, NENG2500, "Dealer Service Tool Catalog" for tools and supplies suitable to collect and contain fluids on Cat® products.

Dispose of all fluids according to local regulations and mandates.

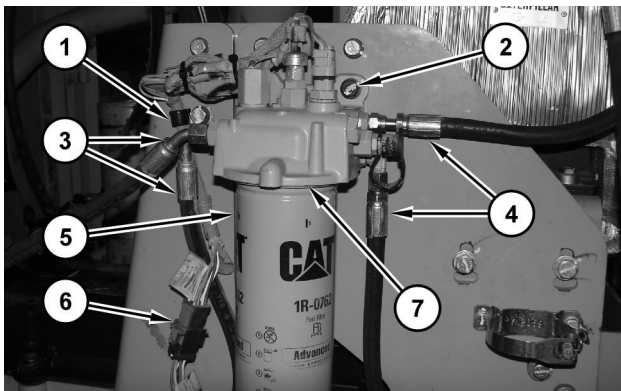

Illustration 194

g01368879

1. Remove clip (1). Disconnect hose assemblies (3) and hose assemblies (4). Use Tooling (A) in order to remove filter assembly (5). Refer to Operation and Maintenance Manual, "Fuel System Secondary Filter - Replace". Disconnect harness assembly (6). Remove bolts (2) in order to remove filter base (7).

Installation Procedure

Table 9

Required Tools			
Tool	Part Number	Part Description	Qty
A	185-3630	Strap Wrench As	1

NOTICE

Keep all parts clean from contaminants.

Contaminants may cause rapid wear and shortened component life.

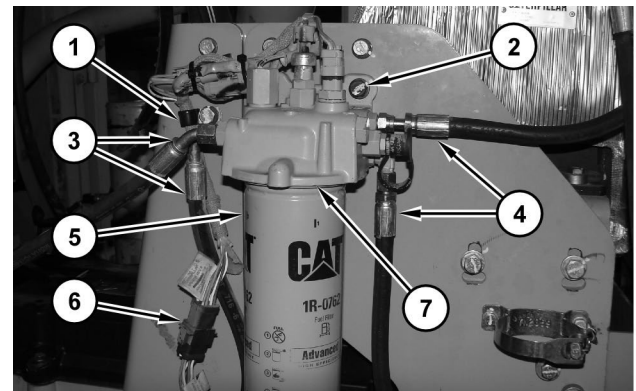

Illustration 195

g01368879

1. Position filter base (7) and install bolts (2). Connect harness assembly (6). Use Tooling (A) in order to install filter assembly (5). Refer to Operation and Maintenance Manual, "Fuel System Secondary Filter - Replace". Connect hose assemblies (4) and hose assemblies (3). Install clip (1).

i02777426

Electric Starting Motor - Remove and Install

SMCS Code: 1453-010

Removal Procedure

NOTICE

Keep all parts clean from contaminants.

Contaminants may cause rapid wear and shortened component life.

WARNING

Personal injury can result from failure to disconnect the battery.

First, disconnect the negative battery cable. Then, disconnect the positive battery cable.

A positive power lead can cause sparks if the battery is not disconnected. Sparks can possibly result in battery explosion or fire.

Note: Put identification marks on all lines, on all hoses, on all wires, and on all tubes for installation purposes. Plug all lines, hoses, and tubes. This helps to prevent fluid loss and this helps to keep contaminants from entering the system.

1. Turn the battery disconnect switch to the OFF position. Remove the key.

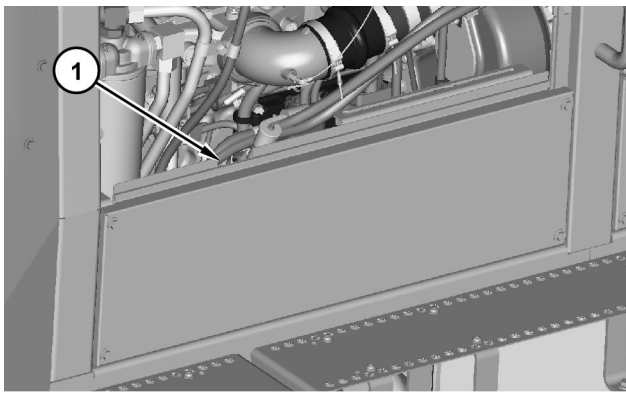

Illustration 196

g01388599

2. Remove panel (1).

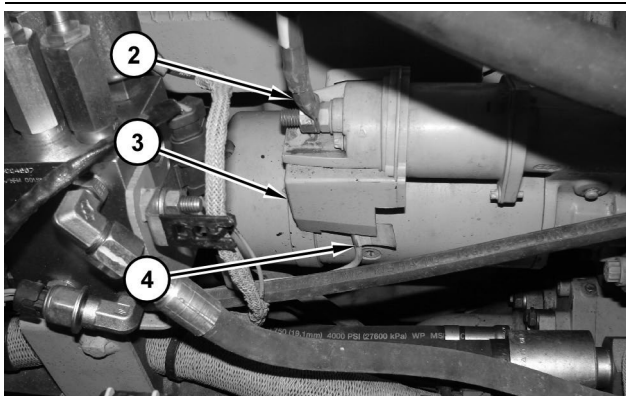

Illustration 197

g01387769

3. Disconnect cable assembly (2). Remove cover (3). Disconnect harness assembly (4).

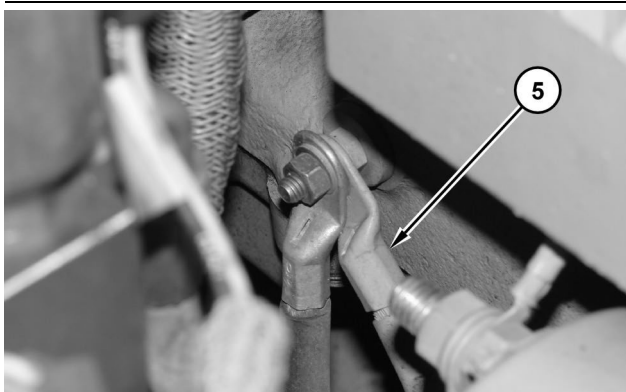

Illustration 198

g01387772

4. Disconnect cable assembly (5).

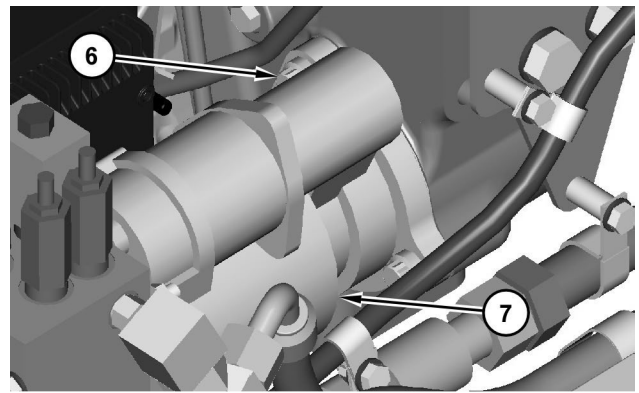

Illustration 199

g01387779

5. Remove bolts (6). Use two people in order to remove electric starting motor (7). The weight of electric starting motor (7) is approximately 27 kg (60 lb).

Installation Procedure

NOTICE

Keep all parts clean from contaminants.

Contaminants may cause rapid wear and shortened component life.

⚠ WARNING

Personal injury can result from failure to disconnect the battery.

First, disconnect the negative battery cable. Then, disconnect the positive battery cable.

A positive power lead can cause sparks if the battery is not disconnected. Sparks can possibly result in battery explosion or fire.

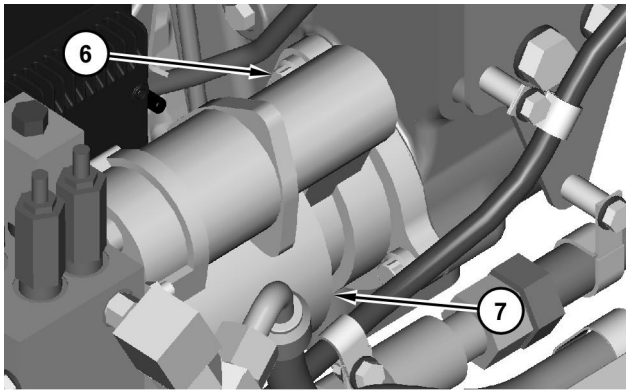

Illustration 200

g01387779

1. Use two people in order to install electric starting motor (7). The weight of electric starting motor (7) is approximately 27 kg (60 lb).
2. Install bolts (6).

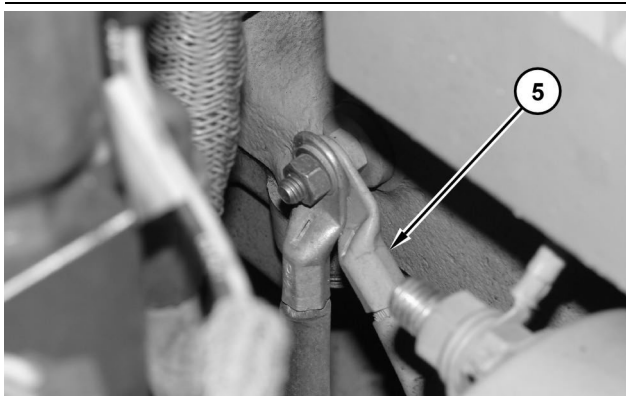

Illustration 201

g01387772

3. Connect cable assembly (5).

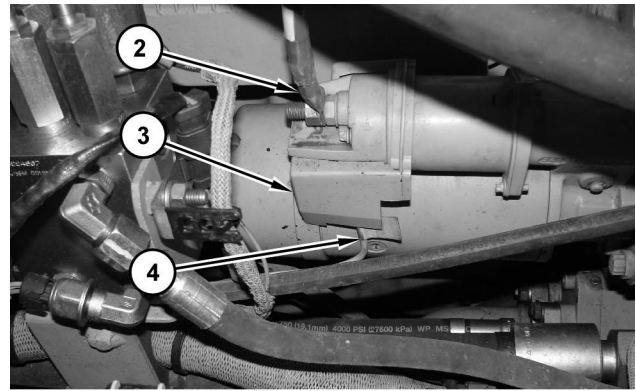

Illustration 202

g01387769

4. Connect harness assembly (4). Tighten the nut for harness assembly (5) to a torque of $2.25 \pm .25 \text{ N}\cdot\text{m}$ ($20 \pm 2 \text{ lb in}$). Install cover (3). Connect cable assembly (2). Tighten the nut for cable assembly (2) to a torque of $30.5 \pm 3.5 \text{ N}\cdot\text{m}$ ($23 \pm 3 \text{ lb ft}$).

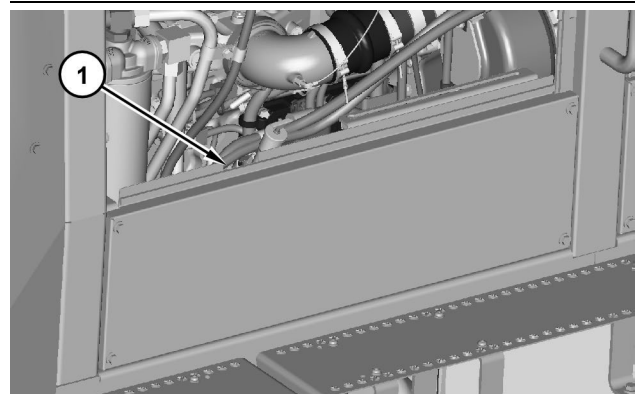

Illustration 203

g01388599

5. Install panel (1).
6. Install the key. Turn the battery disconnect switch to the ON position.

End By:

- a. Install the fuel tank from the right side of the machine. Refer to Disassembly and Assembly, RENR4193, "Fuel Tank - Install".

i02733494

Radiator Guard and Support, Aftercooler, Hydraulic Oil Cooler, and Radiator - Remove

SMCS Code: 1063-011; 1353-011; 1374-011; 7155-011

Removal Procedure

Table 10

Required Tools			
Tool	Part Number	Part Description	Qty
A	138-7575	Link Bracket	4

Start By:

- a. Remove the engine enclosure. Refer to Disassembly and Assembly, "Engine Enclosure - Remove and Install".
1. Drain the engine coolant into a suitable container for storage or disposal. Refer to Operation and Maintenance Manual, "Cooling System Extended Life Coolant - Change".
 2. Drain the hydraulic oil into a suitable container for storage or disposal. Refer to Operation and Maintenance Manual, "Hydraulic System Oil - Change".
 3. Turn the battery disconnect switch to the OFF position.

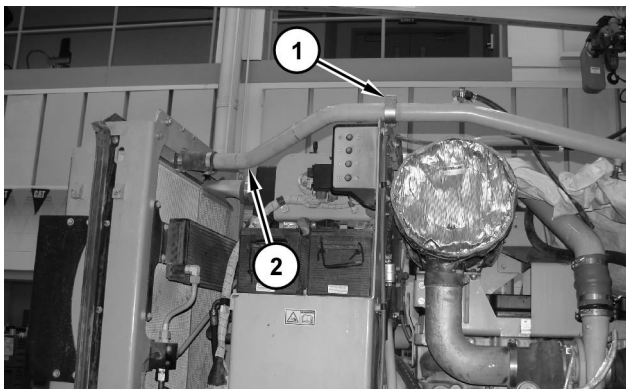

Illustration 204

g01371193

4. Remove clamps (1). Remove tube (2).

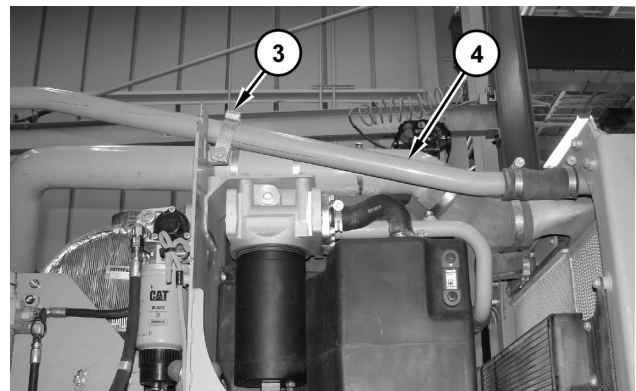

Illustration 205

g01371205

5. Remove clamps (3). Remove tube (4).

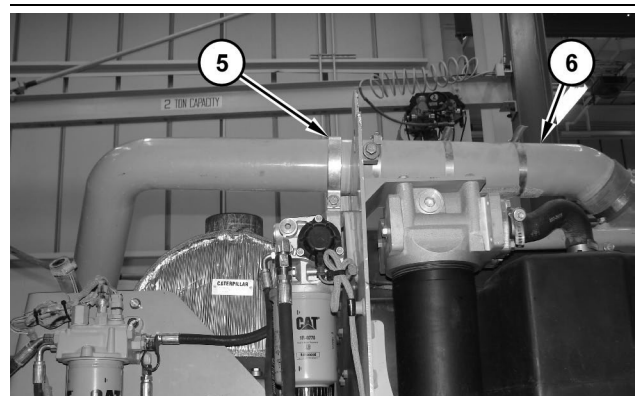

Illustration 206

g01371213

6. Remove clamps (5). Remove tube (6).

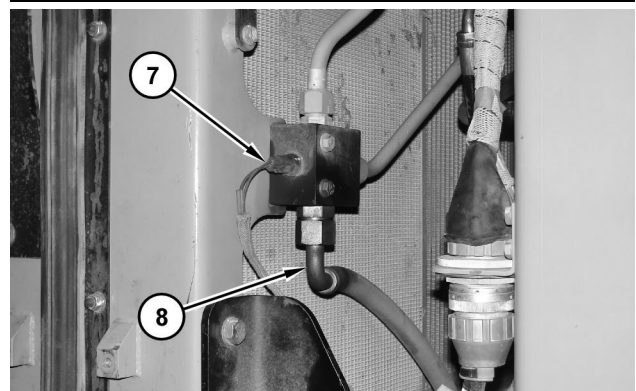

Illustration 207

g01371216

7. Disconnect harness assembly (7). Disconnect hose assembly (8).

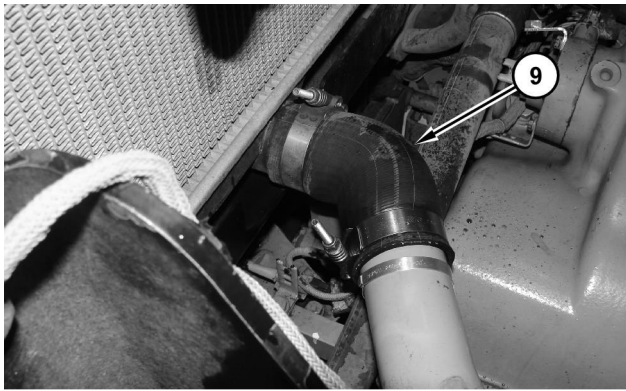

Illustration 208 g01371219

8. Disconnect hose (9).

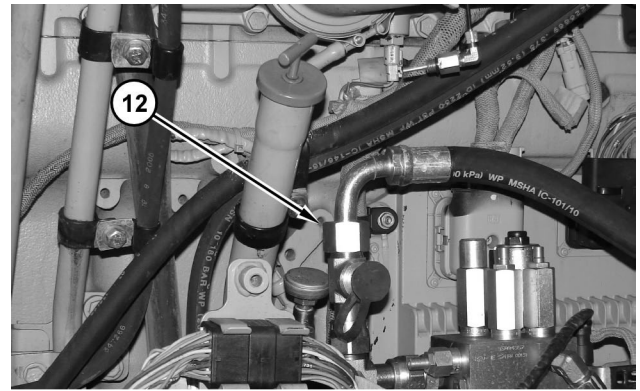

Illustration 211 g01371231

11. Disconnect hose assembly (12).

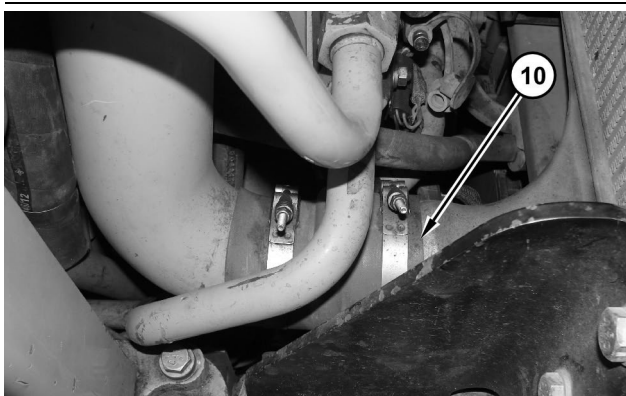

Illustration 209 g01371222

9. Disconnect hose (10).

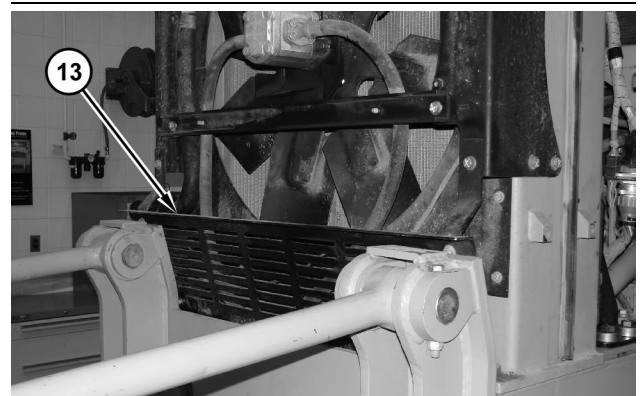

Illustration 212 g01371234

12. Remove guard (13).



Illustration 210 g01371229

10. Disconnect hose assembly (11).

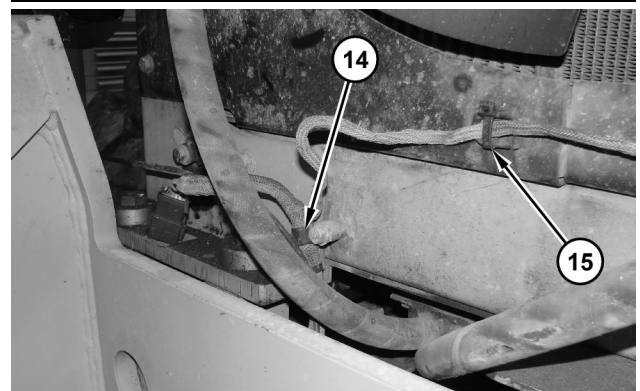

Illustration 213 g01371237

13. Remove clip (14). Remove cable straps (15).

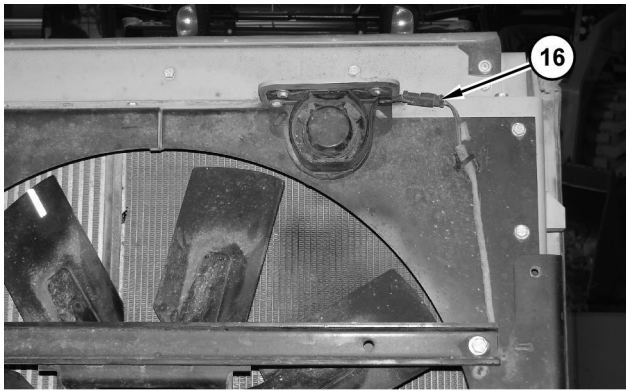

Illustration 214

g01371252

14. Disconnect harness assembly (16). Position harness assembly (16) out of the way.

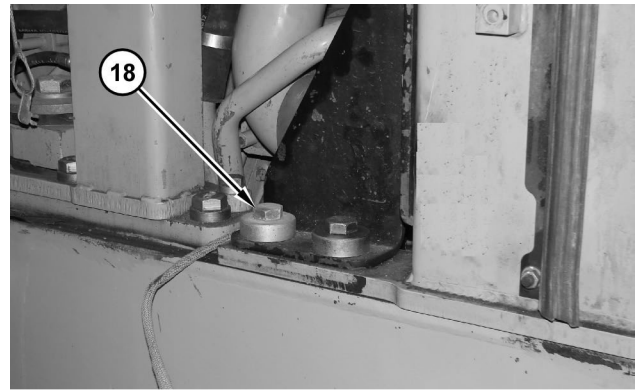

Illustration 216

g01371265

16. Remove bolts (18). Repeat this step for the opposite side.

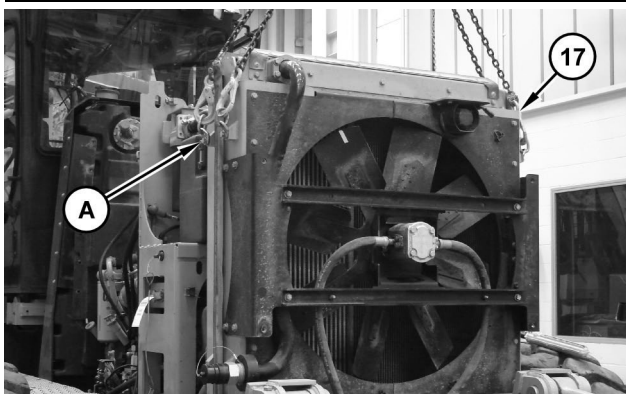

Illustration 215

g01371255

15. Attach Tooling (A) and a suitable lifting device onto radiator guard and support, aftercooler, hydraulic oil cooler, and radiator (17). The weight of radiator guard and support, aftercooler, hydraulic oil cooler, and radiator (17) is approximately 386 kg (850 lb).

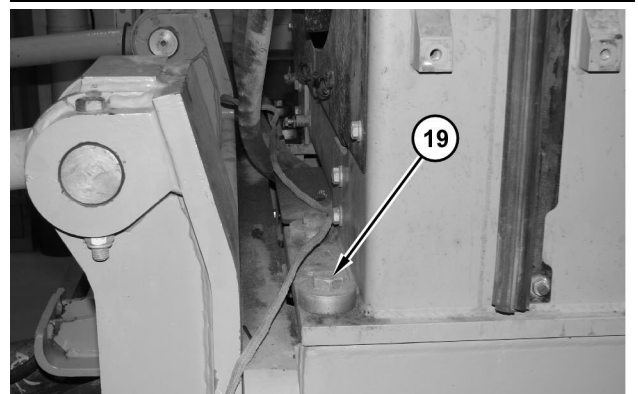

Illustration 217

g01371273

17. Remove bolts (19). Repeat this step for the opposite side.



Illustration 218

g01371277

18. Remove radiator guard and support, aftercooler, hydraulic oil cooler, and radiator (17).

i02735664

Aftercooler - Remove and Install

SMCS Code: 1063-010

Removal Procedure

Table 11

Required Tools			
Tool	Part Number	Description	Qty
A	138-7575	Link Bracket	3

Start By:

- a. Remove the hydraulic oil cooler. Refer to Disassembly and Assembly, "Hydraulic Oil Cooler - Remove and Install".
- b. Remove the engine enclosure. Refer to Disassembly and Assembly, "Engine Enclosure (Hood) - Remove".

NOTICE

Keep all parts clean from contaminants.

Contaminants may cause rapid wear and shortened component life.

NOTICE
Care must be taken to ensure that fluids are contained during performance of inspection, maintenance, testing, adjusting, and repair of the product. Be prepared to collect the fluid with suitable containers before opening any compartment or disassembling any component containing fluids.

Refer to Special Publication, NENG2500, "Dealer Service Tool Catalog" for tools and supplies suitable to collect and contain fluids on Cat® products.

Dispose of all fluids according to local regulations and mandates.

1. Drain the engine coolant into a suitable container for storage or disposal. Refer to Operation and Maintenance Manual, "Cooling System Extended Life Coolant - Change".

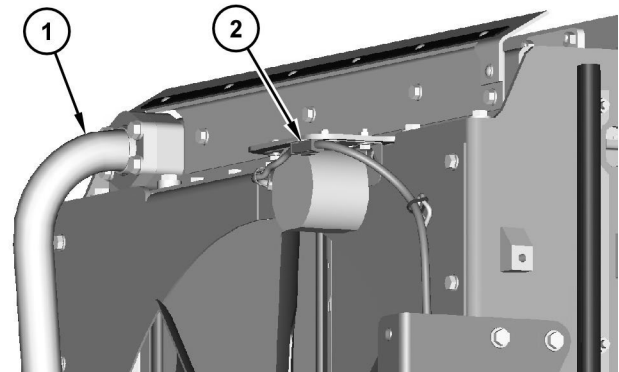

Illustration 219

g01371906

2. Disconnect tube assembly (1). Disconnect harness assembly (2).

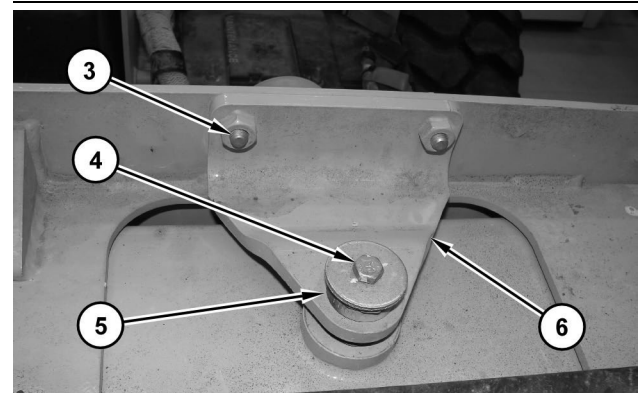

Illustration 220

g01372586

3. Remove bolts (3). Remove bolt (4). Remove mount assembly (5) and bracket (6).

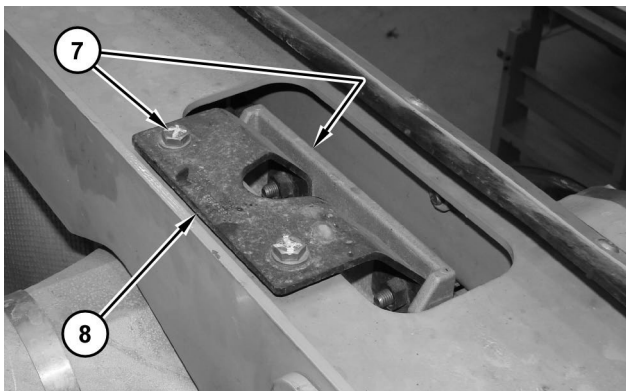

Illustration 221

g01372590

4. Remove bolts (7). Remove bracket (8).

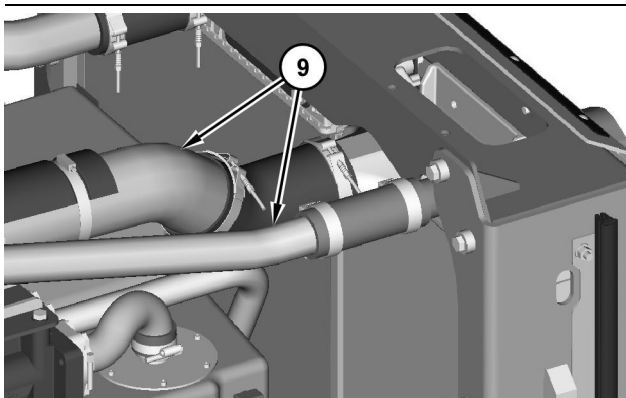

Illustration 222

g01371908

5. Remove tubes (9).

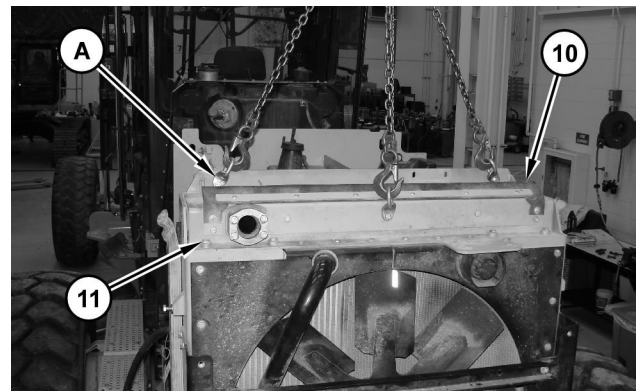

Illustration 223

g01371554

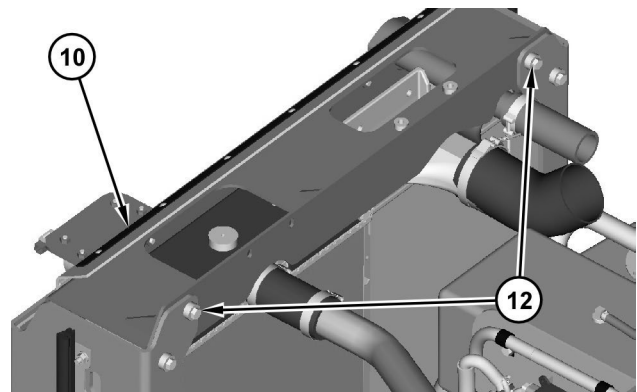

Illustration 224

g01371924

6. Attach Tooling (A) and a suitable lifting device onto bracket assembly (10). The weight of bracket assembly (10) is approximately 39 kg (85 lb). Remove bolts (11). Remove bolts (12). Remove bracket assembly (10).

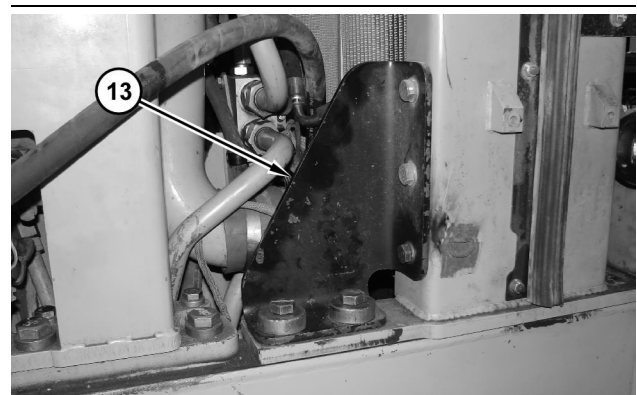

Illustration 225

g01371954

7. Remove bracket (13).

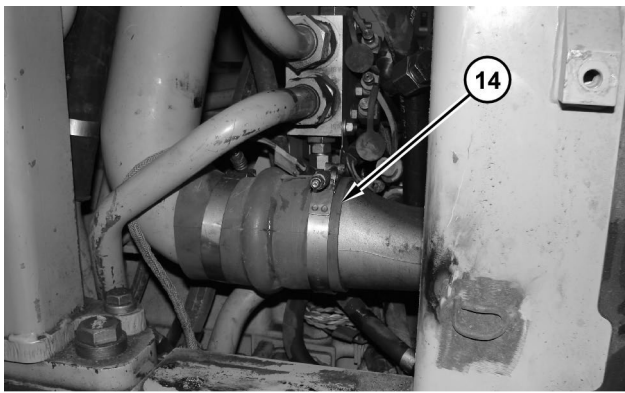

Illustration 226

g01371961

8. Disconnect hose (14).

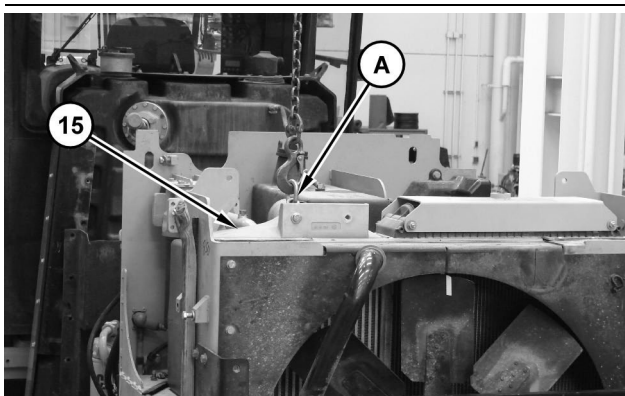

Illustration 227

g01371932

9. Attach Tooling (A) and a suitable lifting device onto aftercooler (15). The weight of aftercooler (15) is approximately 27 kg (60 lb).

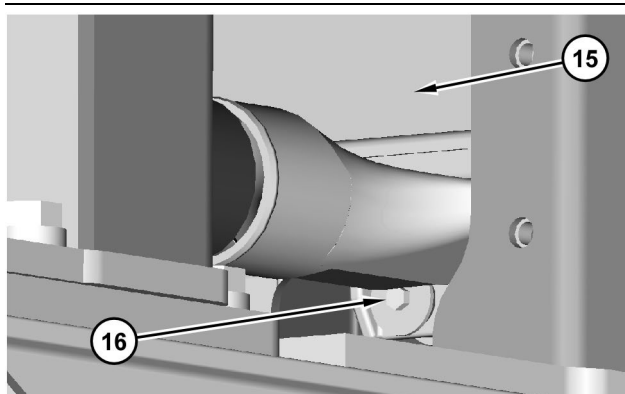

Illustration 228

g01371967

10. Remove bolts (16). Remove aftercooler (15).

Installation Procedure

Table 12

Required Tools			
Tool	Part Number	Description	Qty
A	138 - 7575	Link Bracket	3

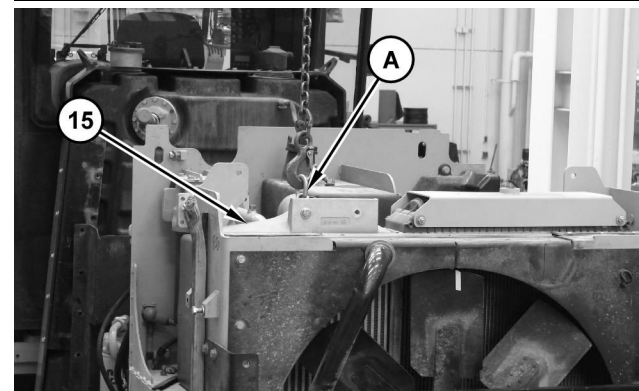

Illustration 229

g01371932

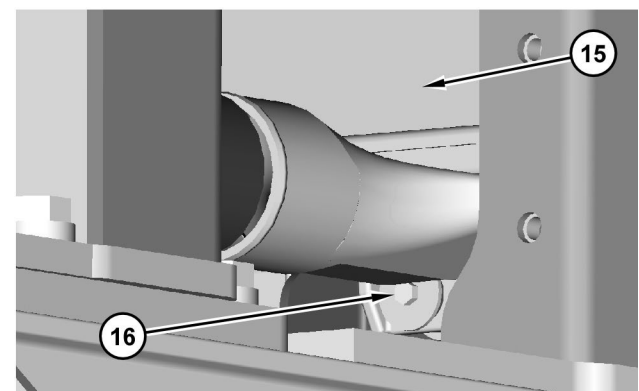

Illustration 230

g01371967

1. Use Tooling (A) and a suitable lifting device in order to install aftercooler (15). The weight of aftercooler (15) is approximately 27 kg (60 lb).

2. Install bolts (16).

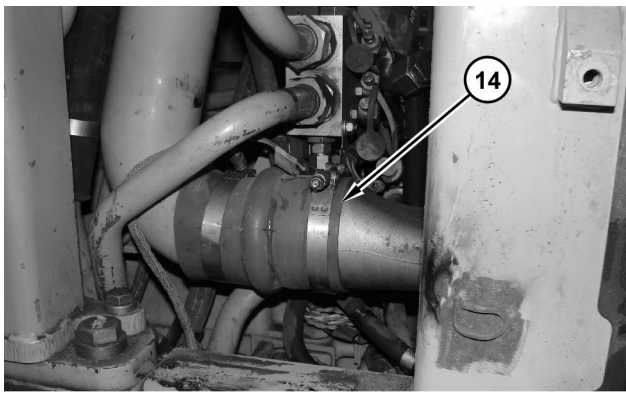

Illustration 231

g01371961

3. Connect hose (14).

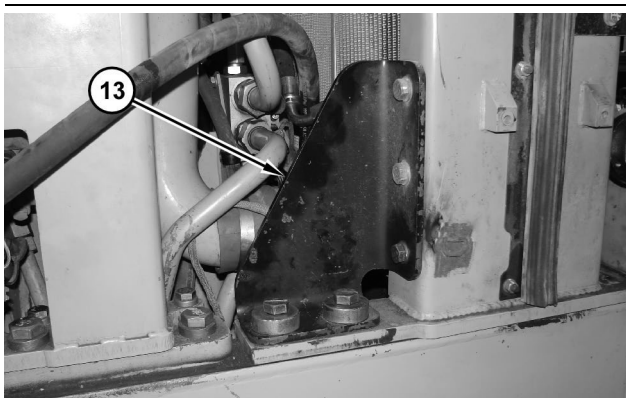

Illustration 232

g01371954

4. Install bracket (13).

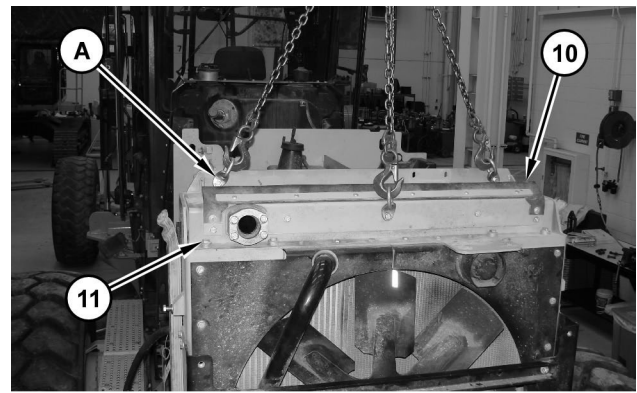

Illustration 233

g01371554

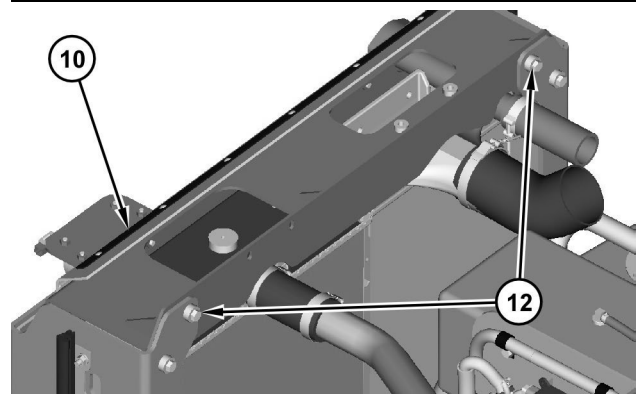

Illustration 234

g01371924

5. Use Tooling (A) and a suitable lifting device in order to install bracket assembly (10). The weight of bracket assembly (10) is approximately 39 kg (85 lb). Install bolts (12). Install bolts (11).

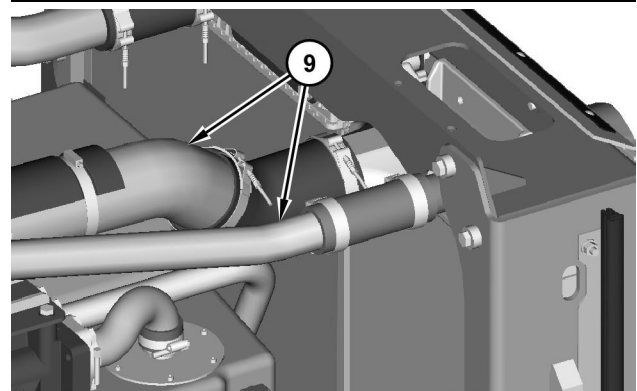

Illustration 235

g01371908

6. Install tubes (9).

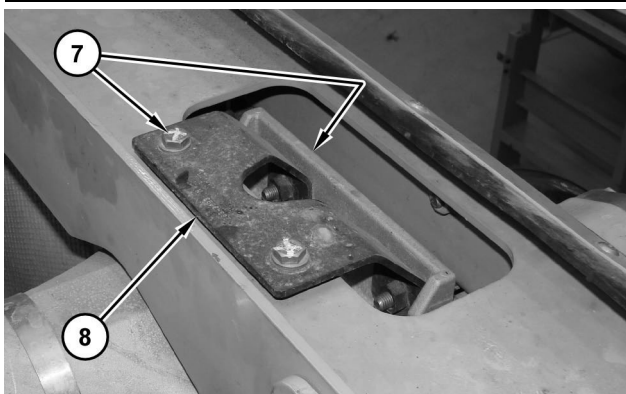

Illustration 236

g01372590

7. Install bracket (8). Install bolts (7).

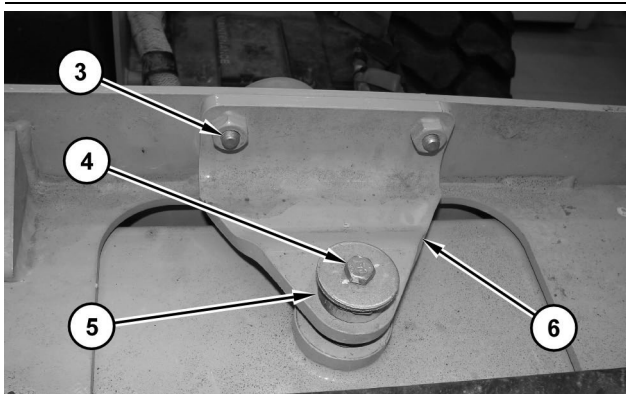

Illustration 237

g01372586

8. Install mount assembly (5) and Install bracket (6). Install bolt (4). Install bolts (3).

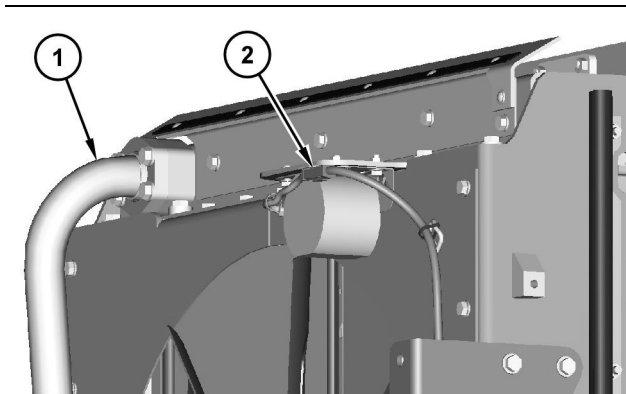

Illustration 238

g01371906

9. Connect harness assembly (2). Connect tube assembly (1).

10. Fill the engine coolant. Refer to Operation and Maintenance Manual, "Cooling System Extended Life Coolant - Change".

End By:

a. Install the engine enclosure. Refer to Disassembly and Assembly, "Engine Enclosure (Hood) - Install".

b. Install the hydraulic oil cooler. Refer to Disassembly and Assembly, "Hydraulic Oil Cooler - Remove and Install".

i02733495

Radiator Guard and Support, Aftercooler, Hydraulic Oil Cooler, and Radiator, - Install

SMCS Code: 1063-012; 1353-012; 1374-012; 7155-010

Installation Procedure

Table 13

Required Tools			
Tool	Part Number	Part Description	Qty
A	138 - 7575	Link Bracket	2

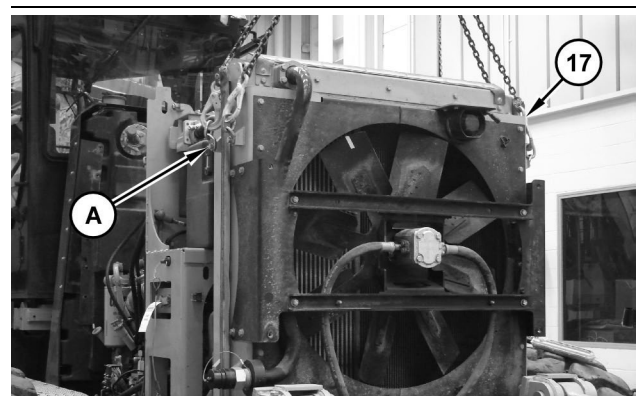

Illustration 239

g01371255

1. Use Tooling (A) and a suitable lifting device in order to install radiator guard and support, aftercooler, hydraulic oil cooler, and radiator (17). The weight of radiator guard and support, aftercooler, hydraulic oil cooler, and radiator (17) is approximately 386 kg (850 lb).

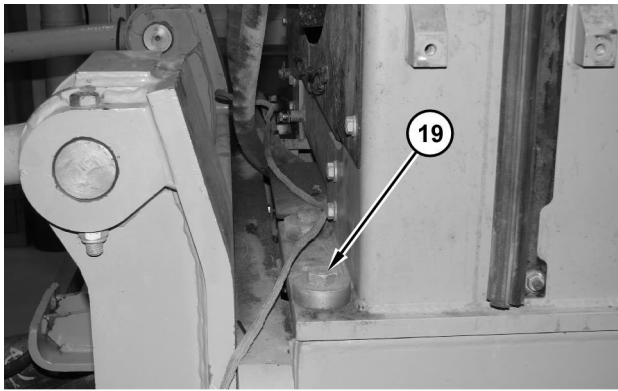

Illustration 240

g01371273

2. Install bolts (19). Repeat this step for the opposite side.

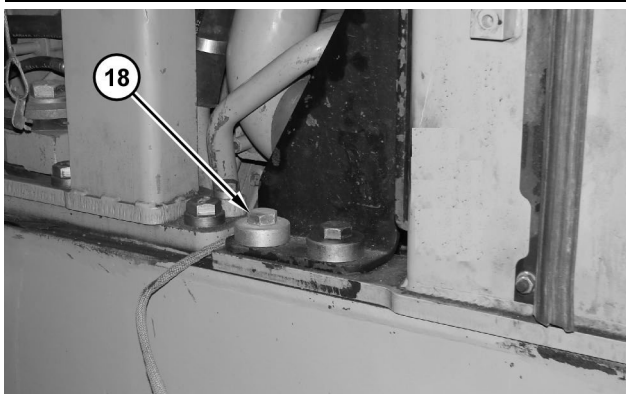

Illustration 241

g01371265

3. Install bolts (18). Repeat this step for the opposite side.

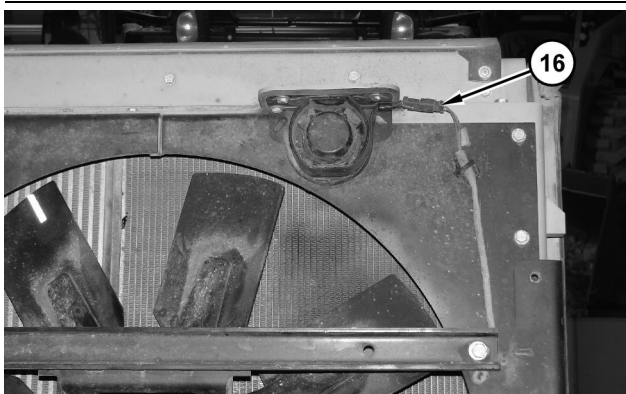

Illustration 242

g01371252

4. Position harness assembly (16). Connect harness assembly (16).

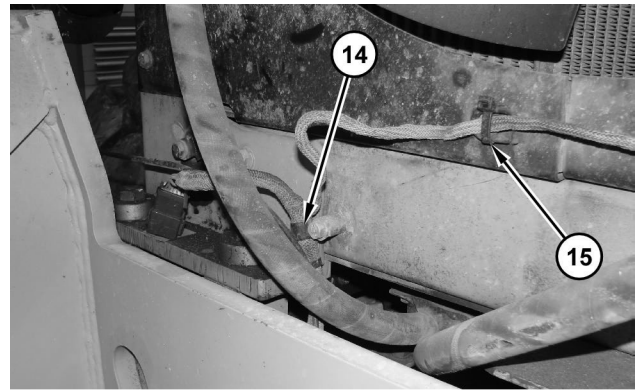

Illustration 243

g01371237

5. Install cable straps (15). Install clip (14).



Illustration 244

g01371234

6. Install guard (13).

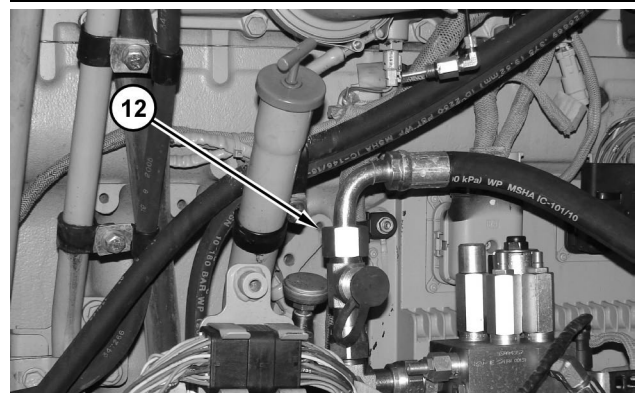

Illustration 245

g01371231

7. Connect hose assembly (12).



Illustration 246 g01371229

8. Connect hose assembly (11).

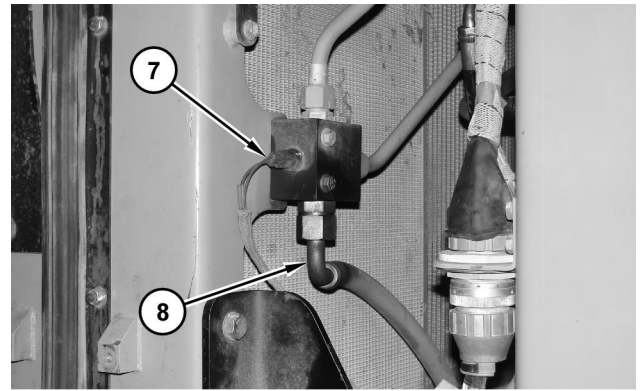

Illustration 249 g01371216

11. Connect hose assembly (8). Connect harness assembly (7).

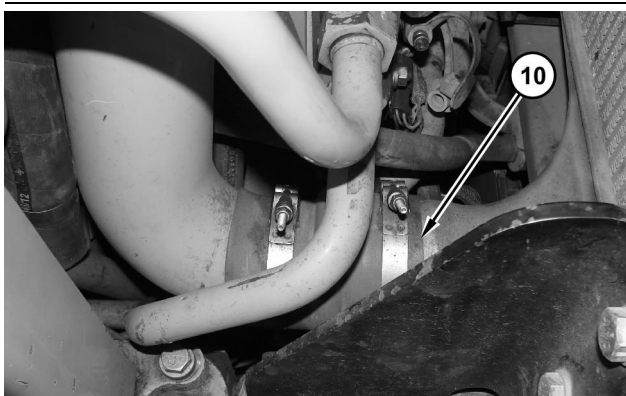

Illustration 247 g01371222

9. Connect hose (10).

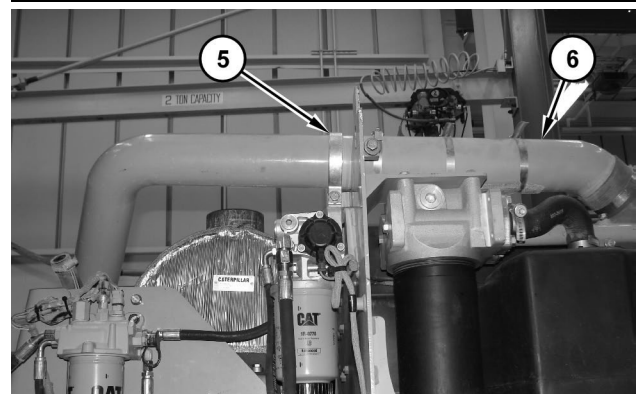

Illustration 250 g01371213

12. Install tube (6). Install clamps (5).



Illustration 248 g01371219

10. Connect hose (9).

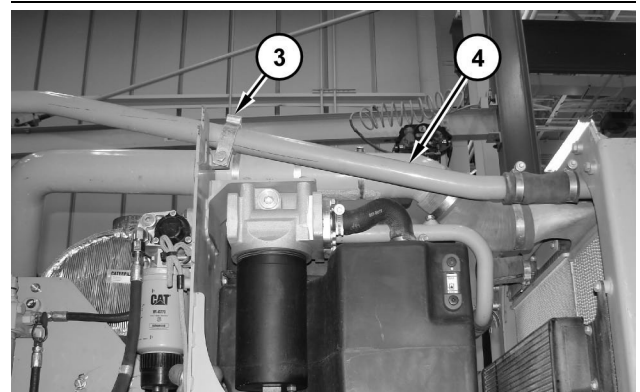

Illustration 251 g01371205

13. Install tube (4). Install clamps (3).

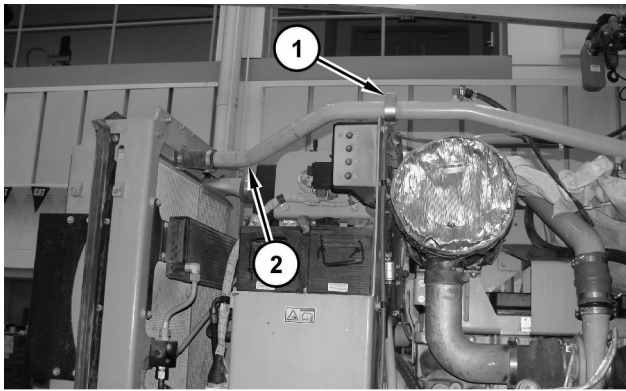

Illustration 252

g01371193

14. Install tube (2). Install clamps (1).
15. Turn the battery disconnect switch to the ON position.
16. Fill the hydraulic oil. Refer to Operation and Maintenance Manual, "Hydraulic System Oil - Change".
17. Fill the engine coolant. Refer to Operation and Maintenance Manual, "Cooling System Extended Life Coolant - Change".

End By:

- a. Install the engine enclosure. Refer to Disassembly and Assembly, "Engine Enclosure - Remove and Install".

i02750358

Radiator - Remove

SMCS Code: 1353-011

Removal Procedure

Table 14

Required Tools			
Tool	Part Number	Part Description	Qty
A	138-7575	Link Bracket	2
B	3E-3882	Eyebolt	1
C	189-0408	Shackle As	1

Start By:

- a. Remove the hydraulic oil cooler. Refer to Disassembly and Assembly, "Hydraulic Oil Cooler - Remove and Install".
- b. Remove the engine enclosure. Refer to Disassembly and Assembly, "Engine Enclosure (Hood) - Remove".

NOTICE

Care must be taken to ensure that fluids are contained during performance of inspection, maintenance, testing, adjusting, and repair of the product. Be prepared to collect the fluid with suitable containers before opening any compartment or disassembling any component containing fluids.

Refer to Special Publication, NENG2500, "Dealer Service Tool Catalog" for tools and supplies suitable to collect and contain fluids on Cat® products.

Dispose of all fluids according to local regulations and mandates.

NOTICE

Keep all parts clean from contaminants.

Contaminants may cause rapid wear and shortened component life.

WARNING

At operating temperature, the engine coolant is hot and under pressure.

Steam can cause personal injury.

Check the coolant level only after the engine has been stopped and the fill cap is cool enough to touch with your bare hand.

Remove the fill cap slowly to relieve pressure.

Cooling system conditioner contains alkali. Avoid contact with the skin and eyes to prevent personal injury.

Note: Put identification marks on all lines, on all hoses, on all wires, and on all tubes for installation purposes. Plug all lines, hoses, and tubes. This helps to prevent fluid loss and this helps to keep contaminants from entering the system.

1. Drain the engine coolant into a suitable container for storage or disposal. Refer to Operation and Maintenance Manual, "Cooling System Extended Life Coolant - Change".

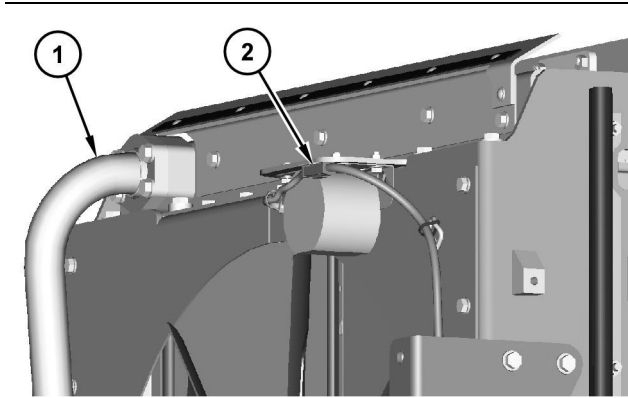

Illustration 253

g01371906

2. Disconnect tube assembly (1). Disconnect harness assembly (2).

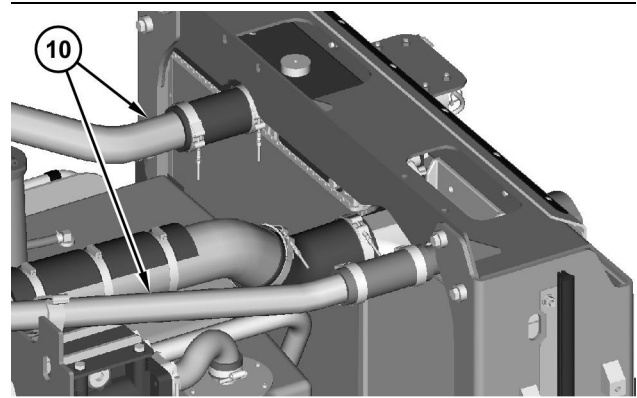

Illustration 256

g01372009

5. Remove tubes (10).

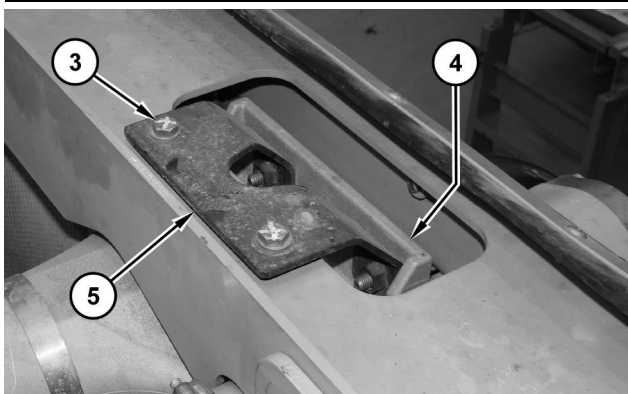

Illustration 254

g01372170

3. Remove bolts (3). Remove bolts (4). Remove bracket (5).

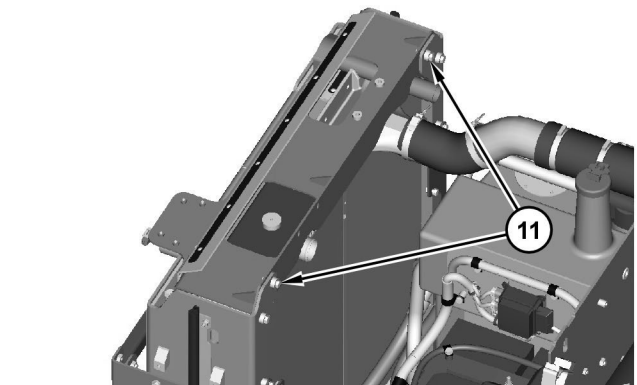

Illustration 257

g01372011

6. Remove bolts (11).

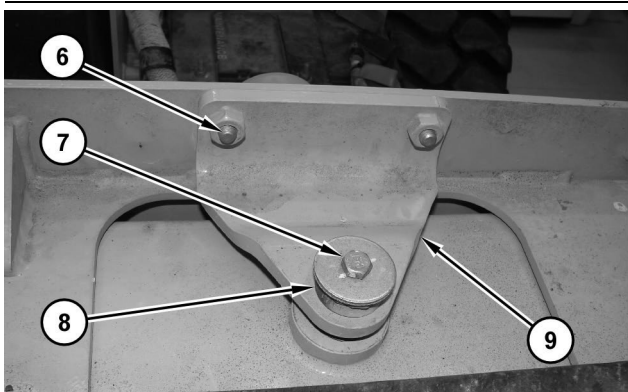

Illustration 255

g01372096

4. Remove bolts (6). Remove bolt (7). Remove mount assembly (8) and bracket (9).

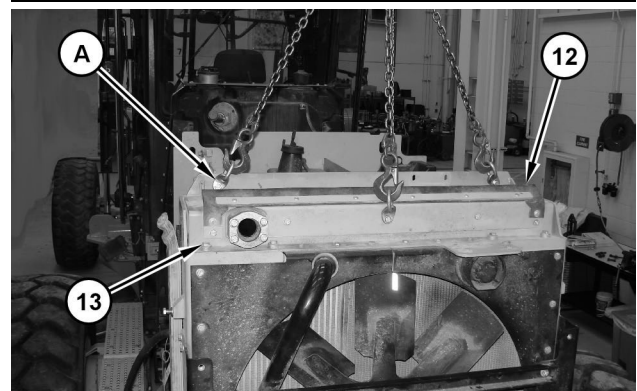

Illustration 258

g01372179

7. Attach Tooling (A) and a suitable lifting device onto bracket assembly (12). The weight of bracket assembly (12) is approximately 39 kg (85 lb). Remove bolts (13). Remove bracket assembly (12).

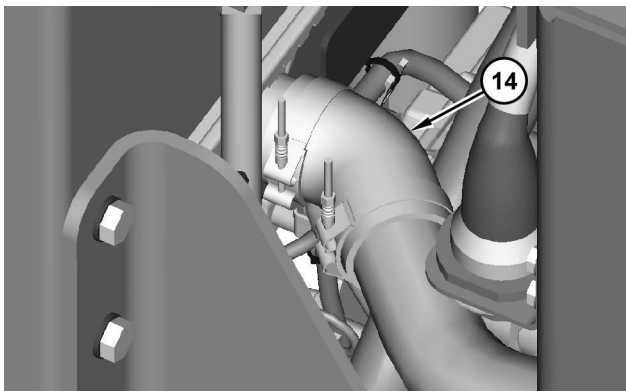

Illustration 259

g01372019

8. Disconnect hose (14).

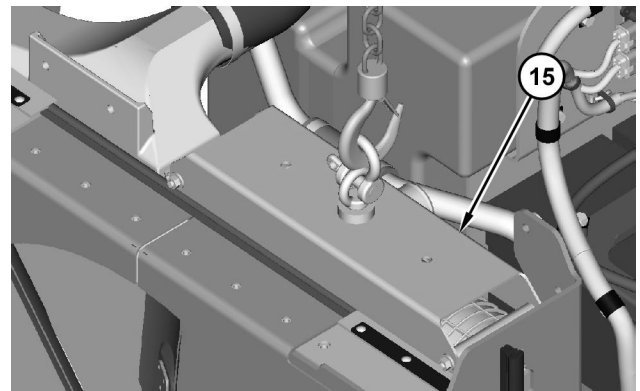

Illustration 262

g01372078

11. Remove radiator (15).

i02750364

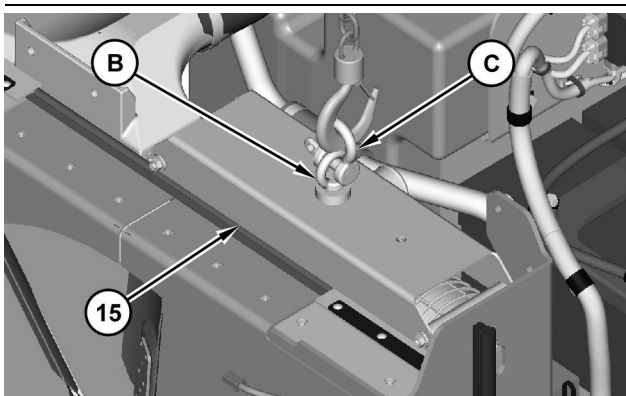

Illustration 260

g01372027

9. Attach Tooling (B), Tooling (C), and a suitable lifting device onto radiator (15). The weight of radiator (15) is approximately 45 kg (100 lb).

Radiator - Install

SMCS Code: 1353-012

Installation Procedure

Table 15

Required Tools			
Tool	Part Number	Part Description	Qty
A	138 - 7575	Link Bracket	2
B	3E - 3882	Eyebolt	1
C	189 - 0408	Shackle As	1

NOTICE

Keep all parts clean from contaminants.

Contaminants may cause rapid wear and shortened component life.

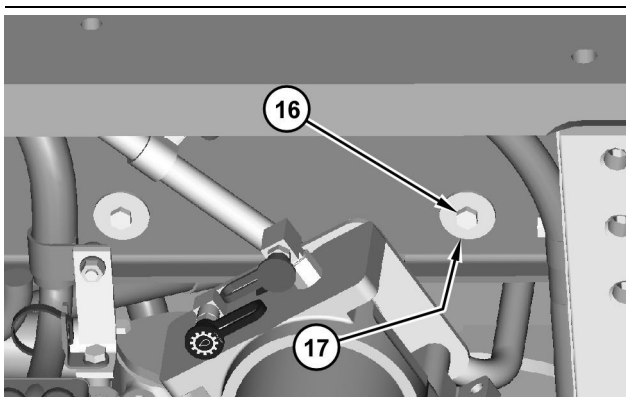

Illustration 261

g01372069

10. Remove bolts (16) and mount assemblies (17).

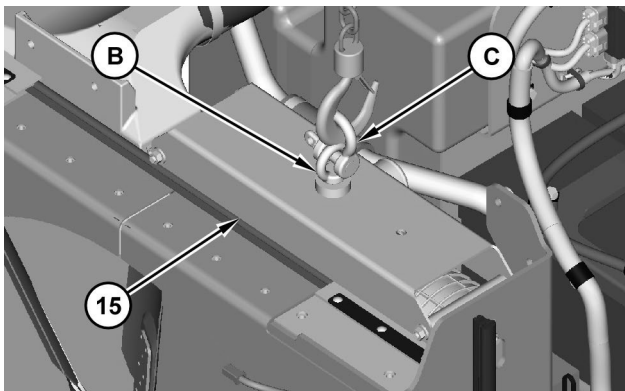

Illustration 263 g01372027

1. Use Tooling (B), Tooling (C), and a suitable lifting device in order to position radiator (15). The weight of radiator (15) is approximately 45 kg (100 lb).

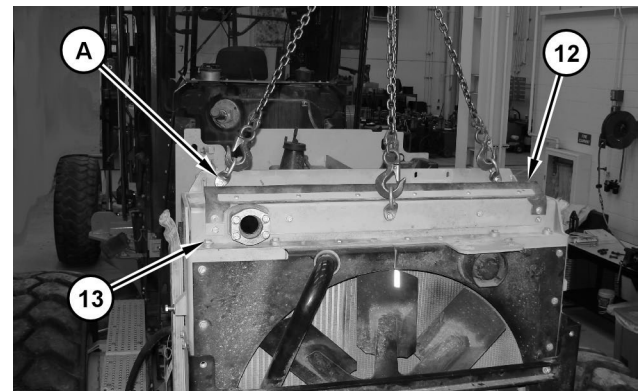

Illustration 266 g01372179

4. Use Tooling (A) and a suitable lifting device in order to install bracket assembly (12). The weight of bracket assembly (12) is approximately 39 kg (85 lb). Install bolts (13).

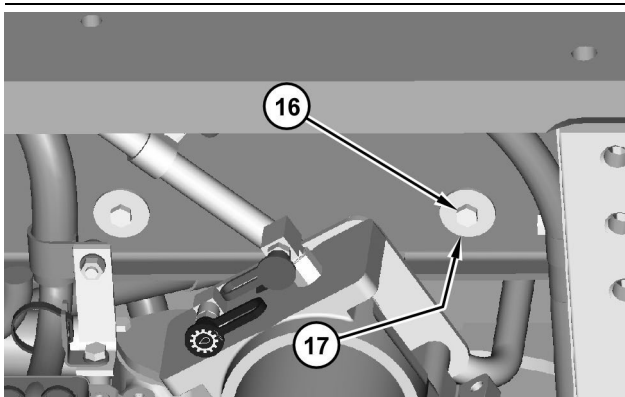

Illustration 264 g01372069

2. Install mount assemblies (17) and bolts (16).

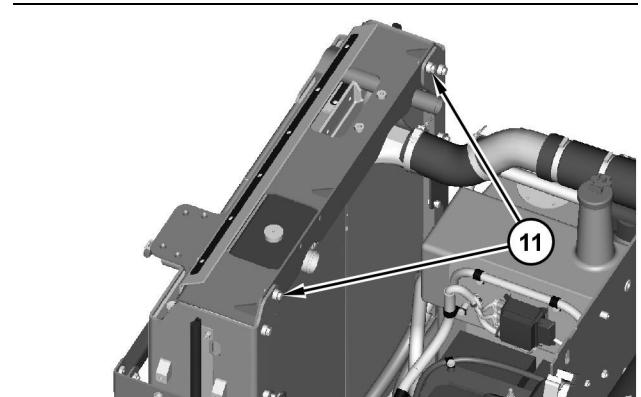

Illustration 267 g01372011

5. Install bolts (11).

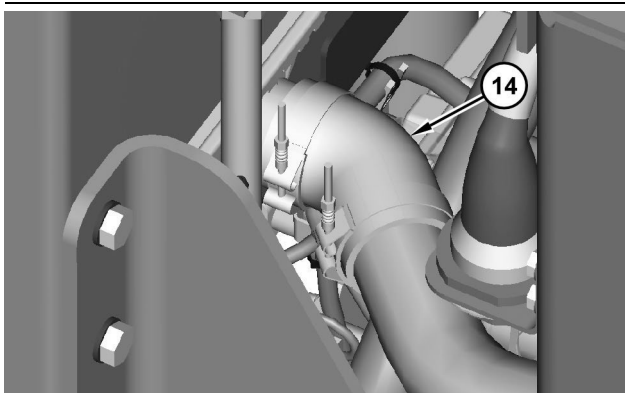

Illustration 265 g01372019

3. Connect hose (14).

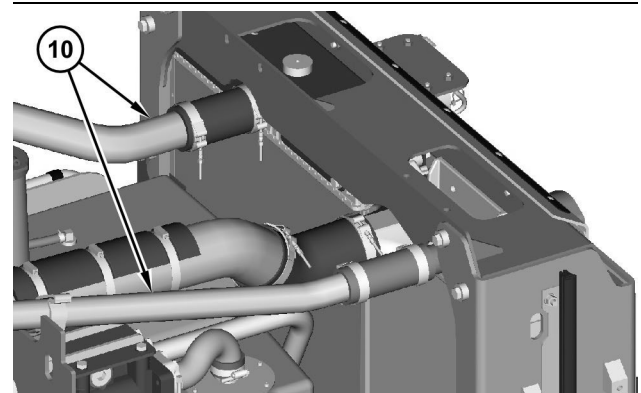

Illustration 268 g01372009

6. Install tubes (10).

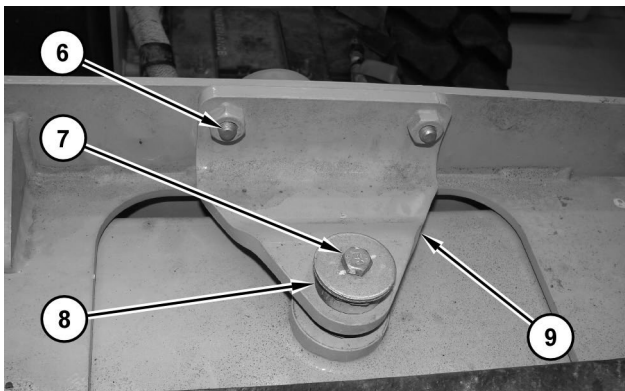

Illustration 269

g01372096

7. Install mount assembly (8) and bracket (9). Install bolt (7). Install bolts (6).

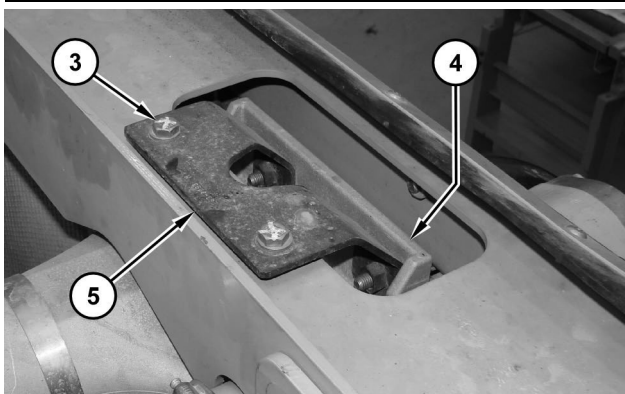

Illustration 270

g01372170

8. Install bracket (5). Install bolts (4). Install bolts (3).

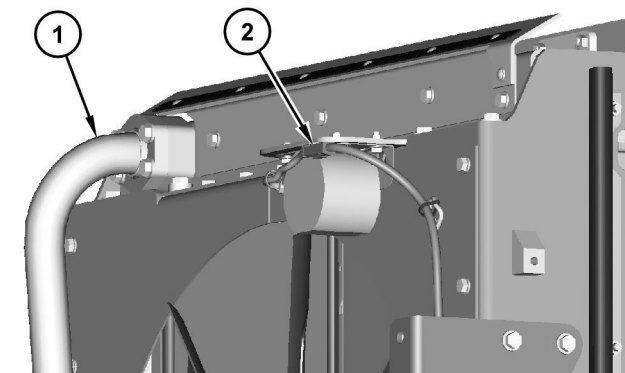

Illustration 271

g01371906

9. Connect harness assembly (2). Connect tube assembly (1).

10. Fill the engine coolant. Refer to Operation and Maintenance Manual, "Cooling System Extended Life Coolant - Change".

End By:

- a. Install the engine enclosure. Refer to Disassembly and Assembly, "Engine Enclosure (Hood) - Install".
- b. Install the hydraulic oil cooler. Refer to Disassembly and Assembly, "Hydraulic Oil Cooler - Remove and Install".

i05565533

Rear Chassis Support - Remove

SMCS Code: 7509-011

Removal Procedure

Table 16

Required Tools			
Tool	Part Number	Part Description	Qty
A	189-0408	Shackle As	2
B	140-7742	Sleeve	2

Start By:

- a. Remove the engine enclosure. Refer to Disassembly and Assembly, "Engine Enclosure - Remove and Install".

NOTICE

Keep all parts clean from contaminants.

Contaminants may cause rapid wear and shortened component life.

NOTICE

Care must be taken to ensure that fluids are contained during performance of inspection, maintenance, testing, adjusting, and repair of the product. Be prepared to collect the fluid with suitable containers before opening any compartment or disassembling any component containing fluids.

Refer to Special Publication, NENG2500, "Dealer Service Tool Catalog" for tools and supplies suitable to collect and contain fluids on Cat® products.

Dispose of all fluids according to local regulations and mandates.

⚠ WARNING

Personal injury can result from hydraulic oil pressure and hot oil.

Hydraulic oil pressure can remain in the hydraulic system after the engine has been stopped. Serious injury can be caused if this pressure is not released before any service is done on the hydraulic system.

Make sure all of the work tools have been lowered to the ground, and the oil is cool before removing any components or lines. Remove the oil filler cap only when the engine is stopped, and the filler cap is cool enough to touch with your bare hand.

⚠ WARNING

Personal injury can result from failure to disconnect the battery.

First, disconnect the negative battery cable. Then, disconnect the positive battery cable.

A positive power lead can cause sparks if the battery is not disconnected. Sparks can possibly result in battery explosion or fire.

Note: Put identification marks on all lines, on all hoses, on all wires, and on all tubes for installation purposes. Plug all lines, hoses, and tubes. This helps to prevent fluid loss and this helps to keep contaminants from entering the system.

1. Turn the key for the battery disconnect switch to the OFF position. Remove the key.
2. Drain the engine coolant into a suitable container for storage or disposal. Refer to Operation and Maintenance Manual, "Cooling System Extended Life Coolant - Change".
3. Drain the hydraulic oil into a suitable container for storage or disposal. Refer to Operation and Maintenance Manual, "Hydraulic System Oil - Change".

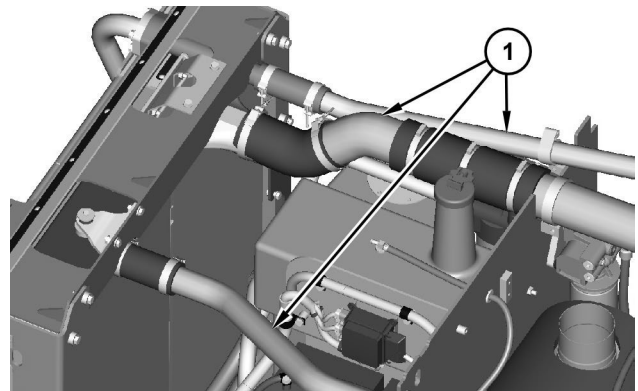

Illustration 272

g01372837

4. Remove tubes (1).

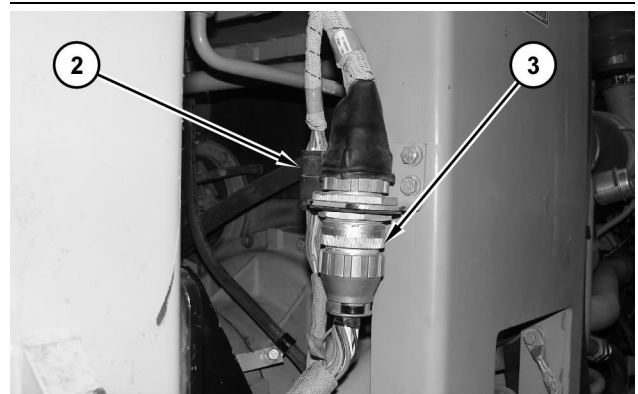

Illustration 273

g01372825

5. Disconnect harness assembly (2). Disconnect harness assembly (3).

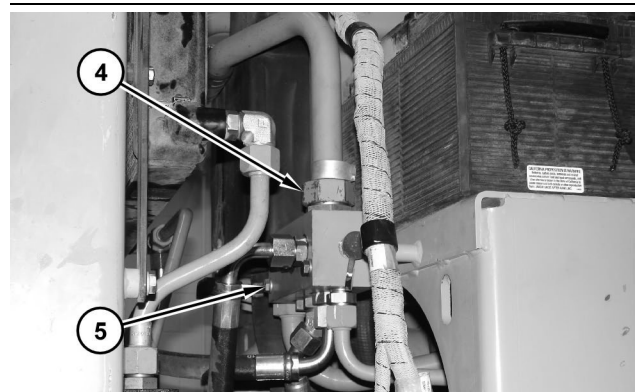

Illustration 274

g01372836

6. Disconnect tube assembly (4). Remove bolts (5).

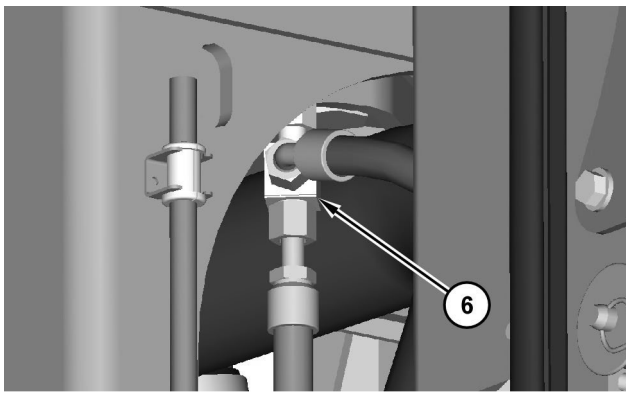

Illustration 275

g01372846

7. Disconnect fitting (6).

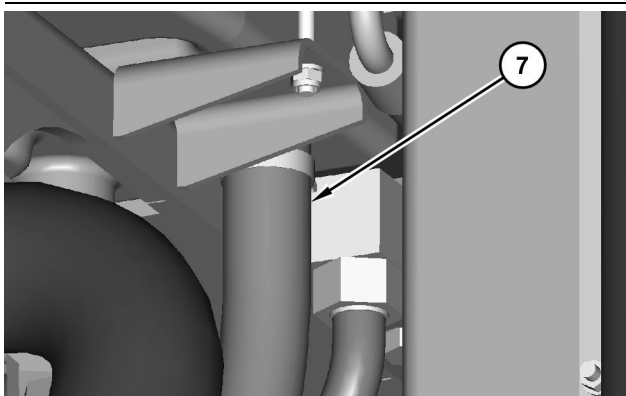

Illustration 276

g01372857

8. Disconnect hose (7).

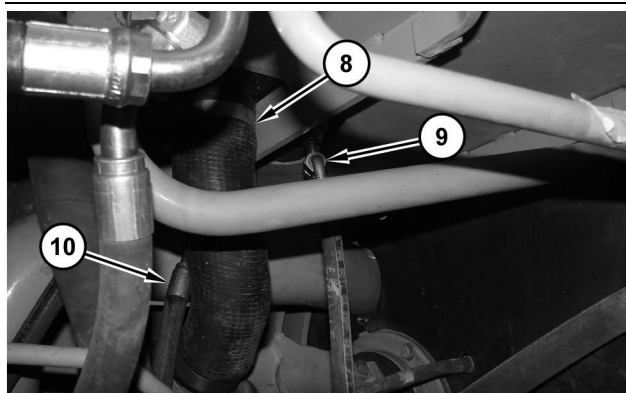

Illustration 277

g01372866

9. Disconnect hose (8). Disconnect hose assembly (9). Disconnect hose assembly (10).

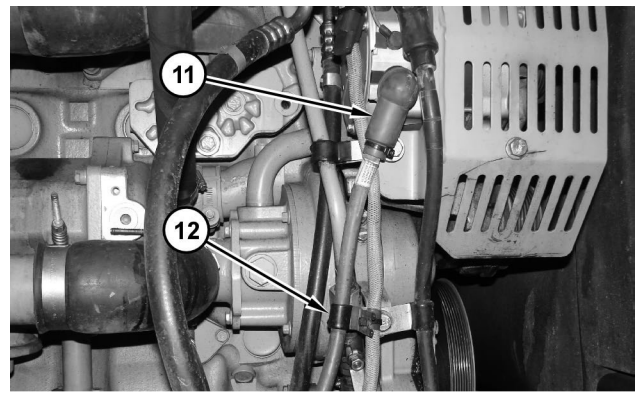

Illustration 278

g01372969

10. Disconnect cable assembly (11). Remove clip (12).



Illustration 279

g01372982

11. Remove clip (13).

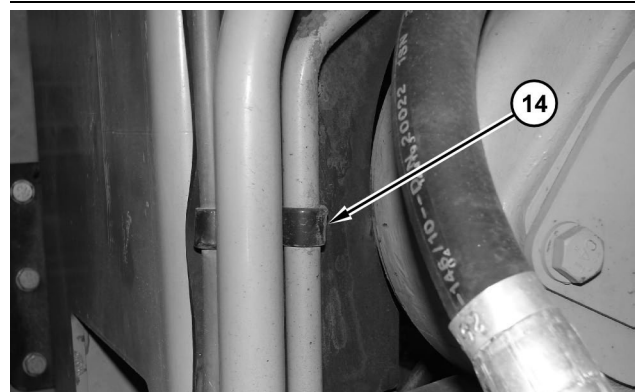

Illustration 280

g01372988

12. Remove clip (14).

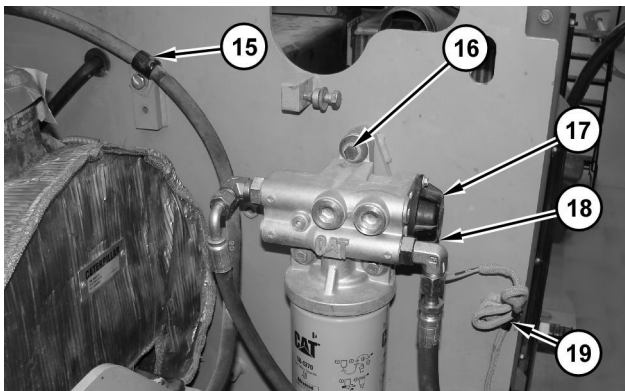

Illustration 281 g01372989

13. Remove clip (15). Remove bolts (16). Disconnect harness assembly (18). Remove clip (19). Position fuel filter and base (17) out of the way.

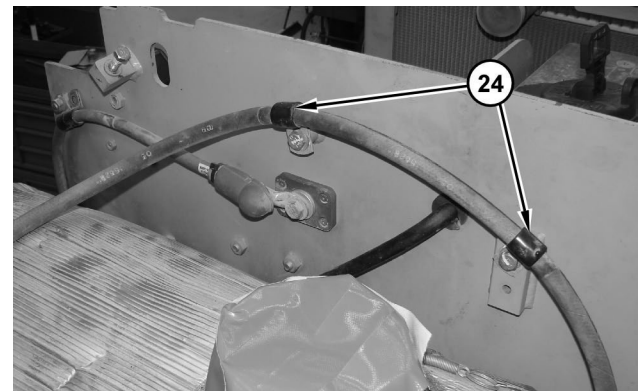

Illustration 284 g01373009

16. Remove clips (24).

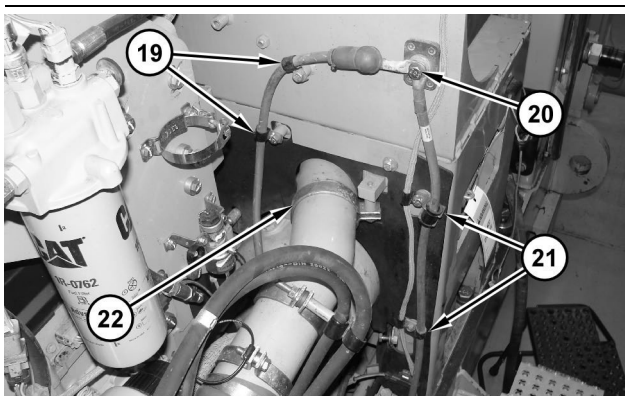

Illustration 282 g01372994

14. Remove clips (19). Remove bolt (20). Remove clips (21). Remove clamp (22).

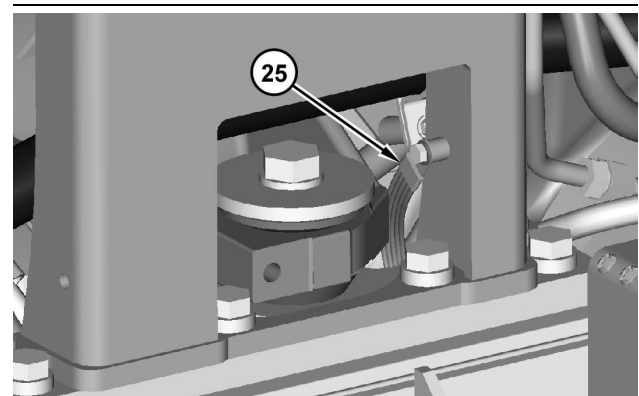

Illustration 285 g01373013

17. Disconnect ground strap (25).

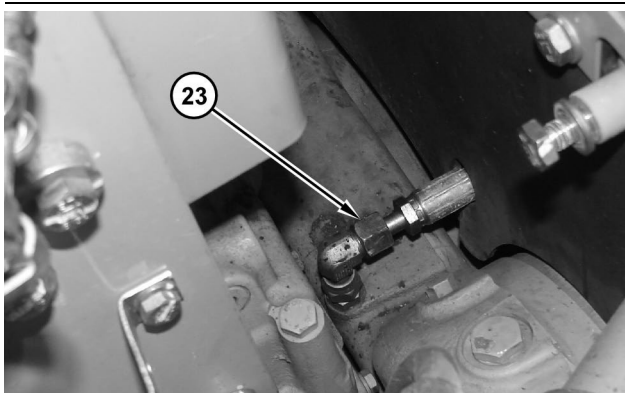

Illustration 283 g01372998

15. Disconnect hose assembly (23).

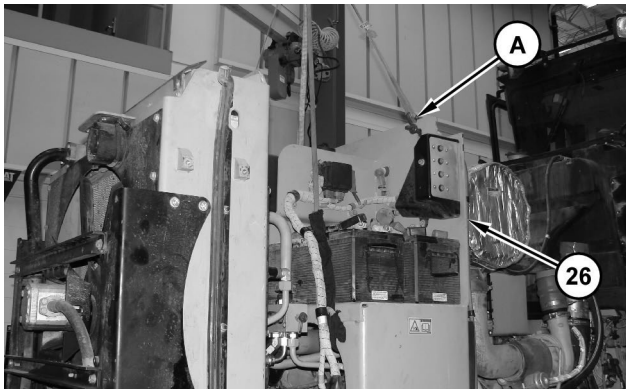

Illustration 286

g01373024

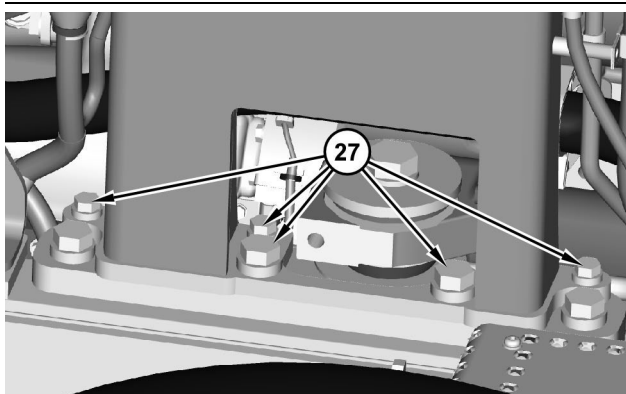

Illustration 287

g03526378

18. Attach Tooling (A), Tooling (B), and two suitable lifting devices onto rear chassis support (26). The weight of rear chassis support (26) is approximately 352 kg (775 lb).
19. Remove bolts (27). Repeat this step for the opposite side.
20. Remove rear chassis support (26).

i02738467

Rear Chassis Support - Install

SMCS Code: 7509-012

Installation Procedure

Table 17

Required Tools			
Tool	Part Number	Part Description	Qty
A	189-0408	Shackle As	2
B	140-7742	Sleeve	2

NOTICE

Keep all parts clean from contaminants.

Contaminants may cause rapid wear and shortened component life.

WARNING

Personal injury can result from failure to disconnect the battery.

First, disconnect the negative battery cable. Then, disconnect the positive battery cable.

A positive power lead can cause sparks if the battery is not disconnected. Sparks can possibly result in battery explosion or fire.

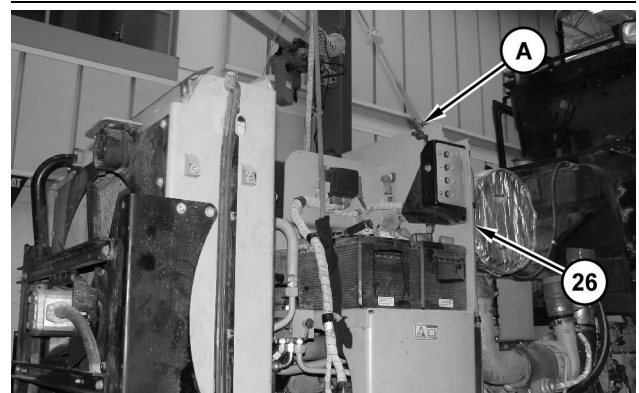

Illustration 288

g01373024



Illustration 289

g01373020

1. Use Tooling (A), Tooling (B), and two suitable lifting devices in order to install rear chassis support (26). The weight of rear chassis support (26) is approximately 352 kg (775 lb).
2. Install bolts (27). Repeat this step for the opposite side.

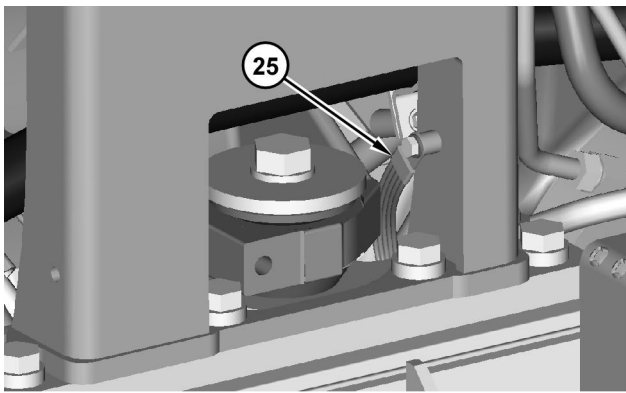

Illustration 290

g01373013

3. Connect ground strap (25).

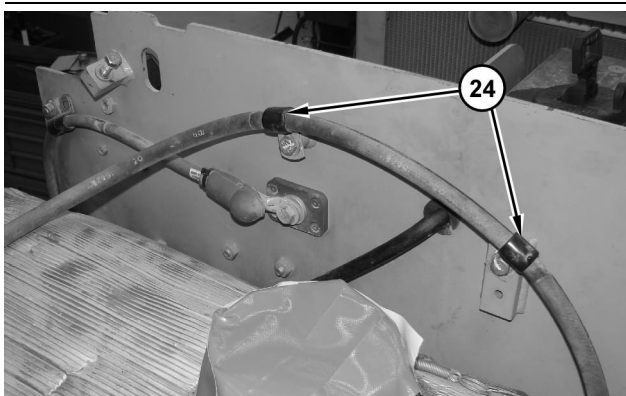

Illustration 291

g01373009

4. Install clips (24).

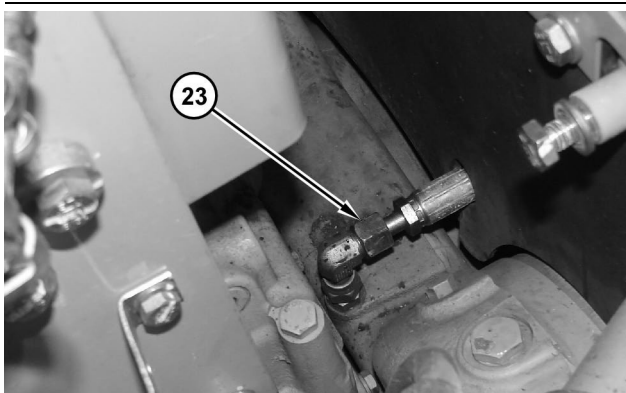

Illustration 292

g01372998

5. Connect hose assembly (23).

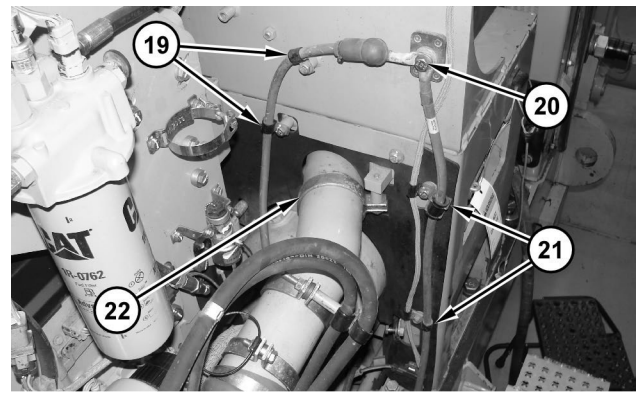

Illustration 293

g01372994

6. Install clamp (22). Install clips (21). Install bolt (20). Install clips (19).

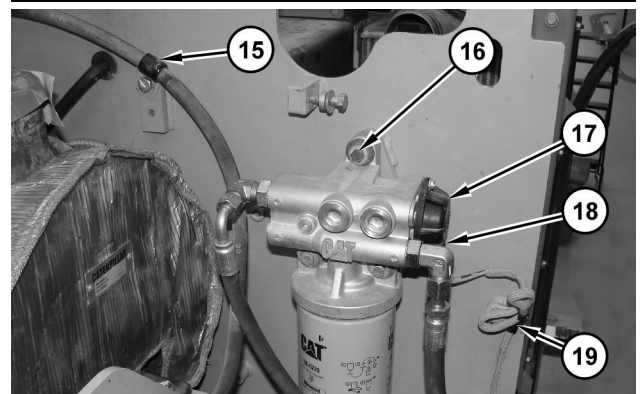

Illustration 294

g01372989

7. Position fuel filter and base (17) and install bolts (16). Install clip (15). Install clip (19). Connect harness assembly (18).

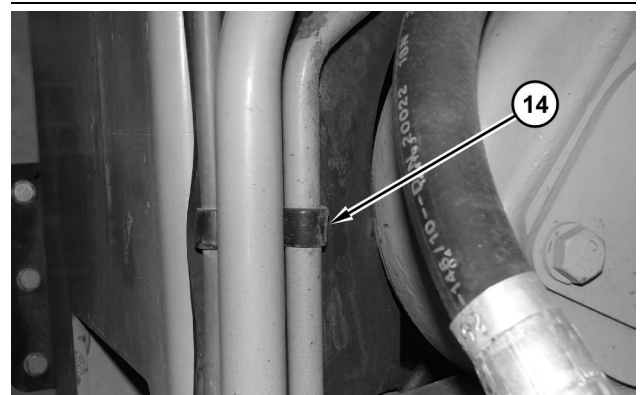

Illustration 295

g01372988

8. Install clip (14).



Illustration 296

g01372982

9. Install clip (13).

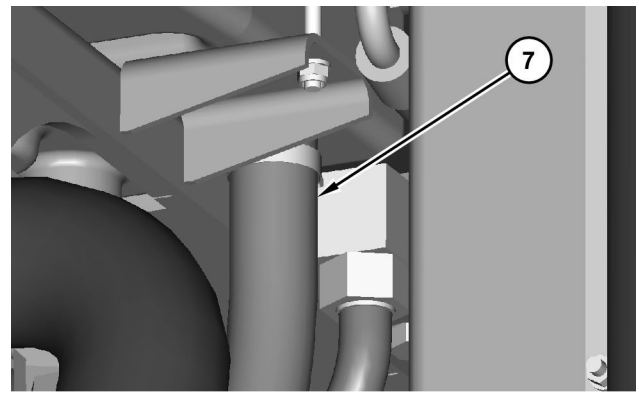

Illustration 299

g01372857

12. Connect hose (7).

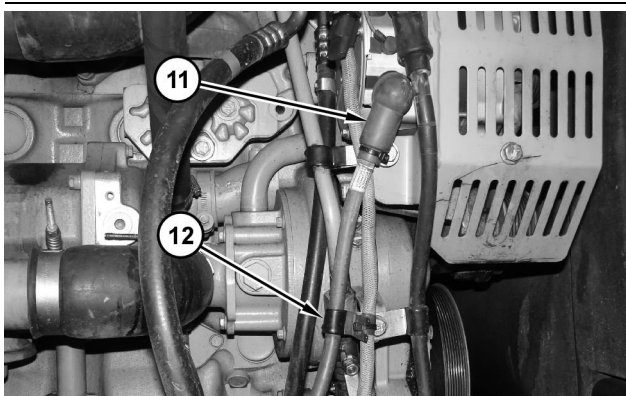

Illustration 297

g01372969

10. Install clip (12). Connect cable assembly (11).

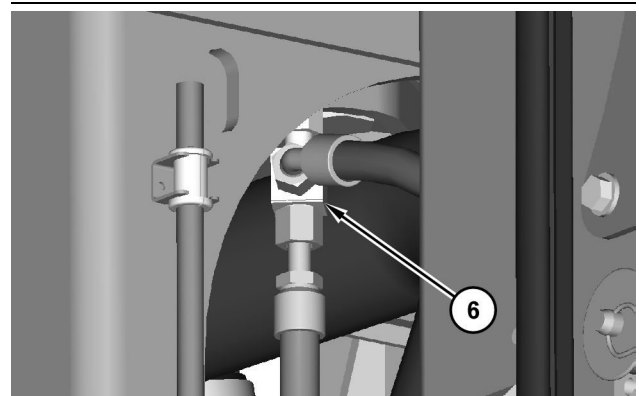

Illustration 300

g01372846

13. Connect fitting (6).

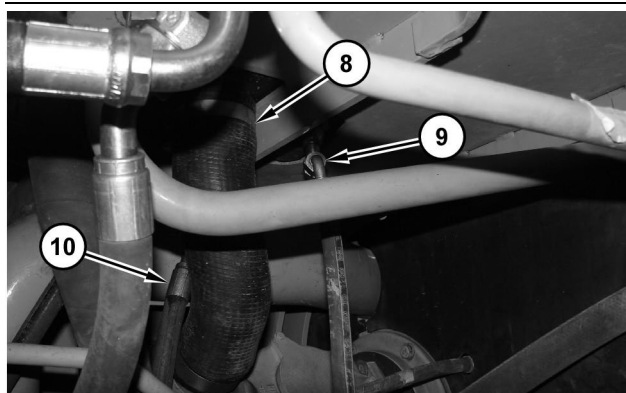

Illustration 298

g01372866

11. Connect hose assembly (10). Connect hose assembly (9). Connect hose (8).



Illustration 301

g01372836

14. Install bolts (5). Connect tube assembly (4).

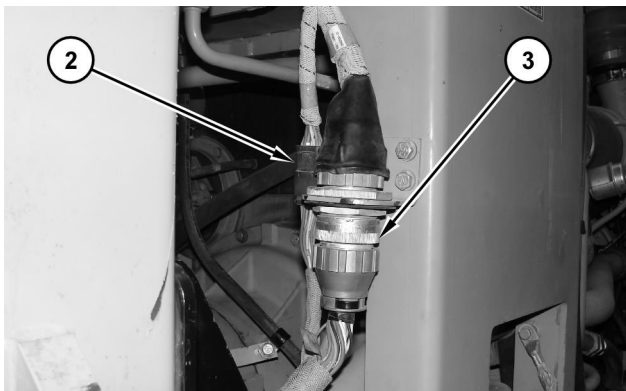

Illustration 302

g01372825

15. Connect harness assembly (3). Connect harness assembly (2).

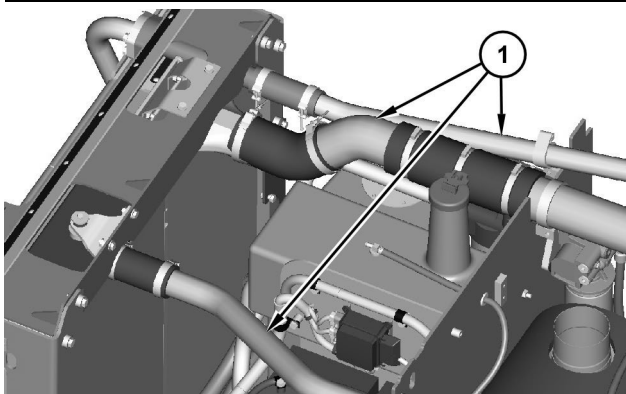

Illustration 303

g01372837

- 16. Install tubes (1).
- 17. Fill the hydraulic oil. Refer to Operation and Maintenance Manual, "Hydraulic System Oil - Change".
- 18. Fill the engine coolant. Refer to Operation and Maintenance Manual, "Cooling System Extended Life Coolant - Change".
- 19. Install the key. Turn the battery disconnect switch to the ON position.

End By:

- a. Install the engine enclosure. Refer to Disassembly and Assembly, "Engine Enclosure - Remove and Install".

i05534736

Flywheel and Rear Gear Group - Remove and Install (Drive Gear)

SMCS Code: 1156-010; 1158-010; 1204-010; 1206-010

Removal Procedure

Table 18

Required Tools			
Tool	Part Number	Part Description	Qty
A	422-8733	Jack Stand Gp	4
B	-	Guide Stud M16 - 2 by 12 in	2
C	138-7573	Link Bracket	1

Start By:

- a. Remove the engine.

NOTICE

Keep all parts clean from contaminants.

Contaminants may cause rapid wear and shortened component life.

NOTICE

Care must be taken to ensure that fluids are contained during performance of inspection, maintenance, testing, adjusting, and repair of the product. Be prepared to collect the fluid with suitable containers before opening any compartment or disassembling any component containing fluids.

Refer to Special Publication, NENG2500, "Dealer Service Tool Catalog" for tools and supplies suitable to collect and contain fluids on Cat® products.

Dispose of all fluids according to local regulations and mandates.

Disassembly and Assembly Section

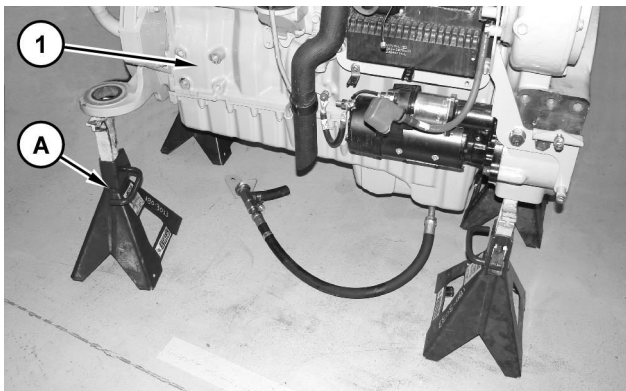

Illustration 304

g01383364

1. Use a suitable lifting device in order to position engine (1) onto Tooling (A). The weight of engine (1) is approximately 1497 kg (3300 lb).

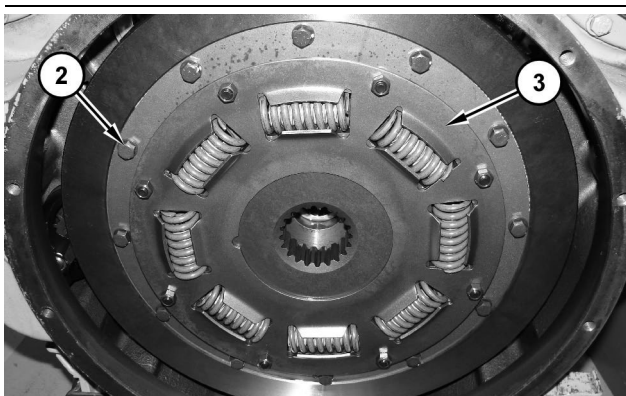

Illustration 305

g01383397

2. Remove bolts (2) and remove coupling (3).

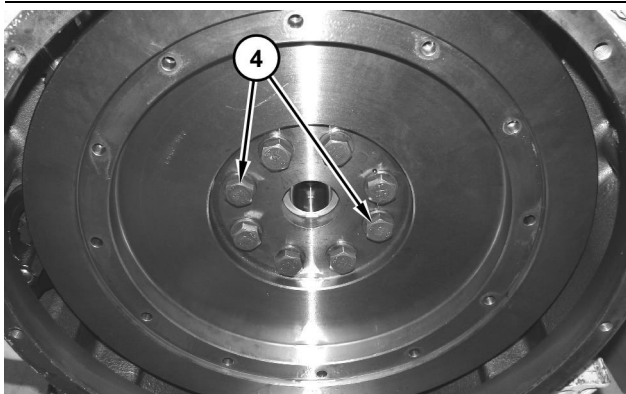

Illustration 306

g01383597

3. Remove bolts (4).

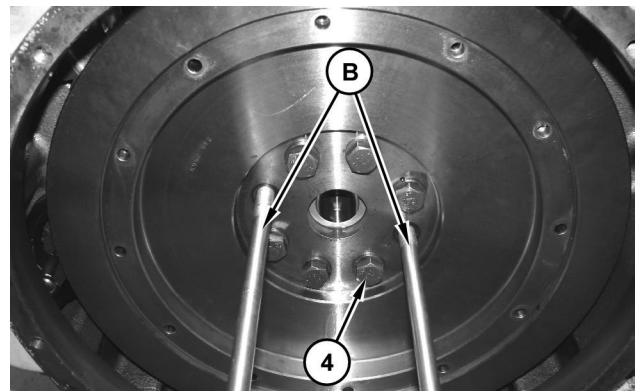

Illustration 307

g01383603

4. Install Tooling (B). Remove remaining bolts (4).

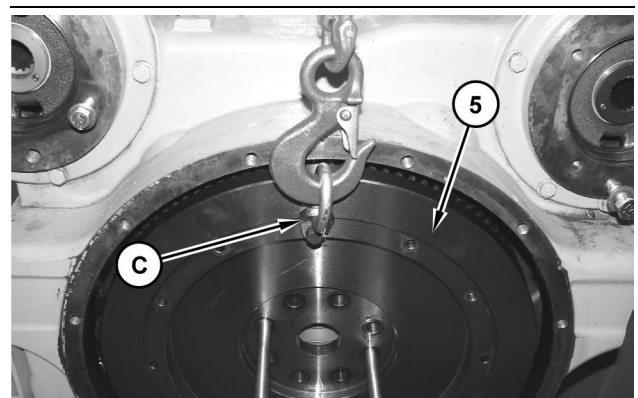

Illustration 308

g01383609

5. Attach Tooling (C) and a suitable lifting device to flywheel (5). The weight of flywheel (5) is approximately 50 kg (110 lb). Remove flywheel (5).

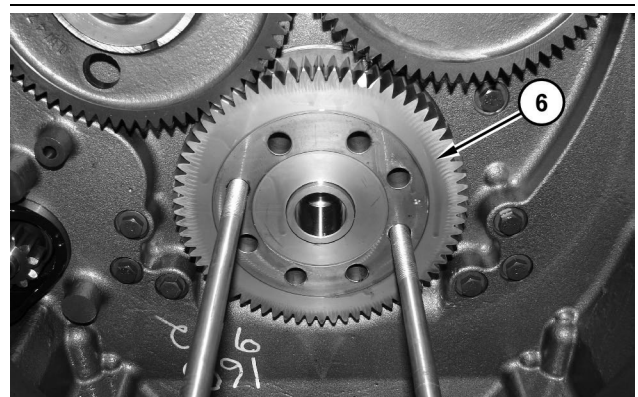

Illustration 309

g01383614

6. Remove drive gear (6).

Installation Procedure

Table 19

Required Tools			
Tool	Part Number	Part Description	Qty
A	422-8733	Jack Stand Gp	4
B	-	Guide Stud M16 - 2 by 12 in	2
C	138-7573	Link Bracket	1
D	-	Loctite 271 Thread Lock Compound	1

NOTICE

Keep all parts clean from contaminants.

Contaminants may cause rapid wear and shortened component life.

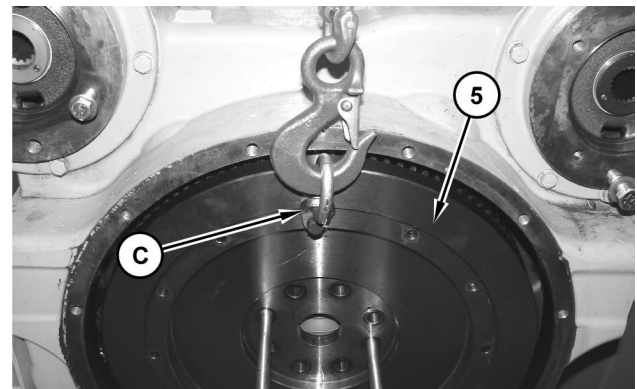

Illustration 311

g01383609

2. Attach Tooling (C) and a suitable lifting device to flywheel (5). The weight of flywheel (5) is approximately 50 kg (110 lb). Install flywheel (5).

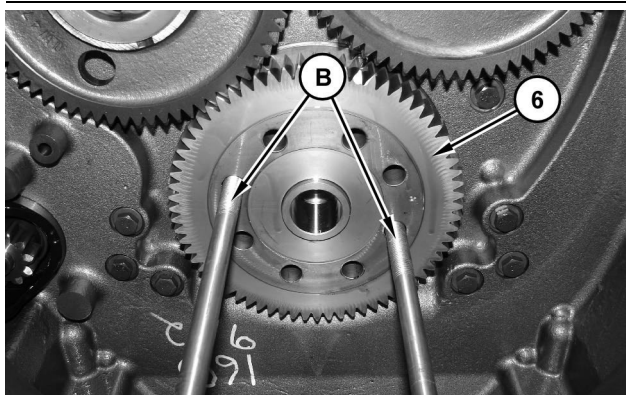

Illustration 310

g01383735

1. Install Tooling (B) in order to aid in the installation of drive gear (6).

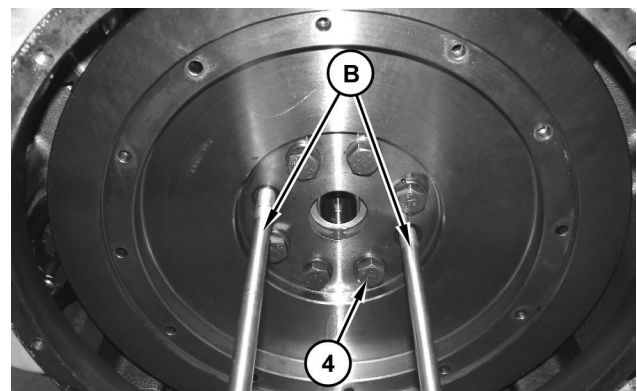

Illustration 312

g01383603

3. Apply Tooling (D) to bolts (4). Install bolts (4). Tighten bolts (4) to a torque of 300 ± 40 N·m (220 ± 30 lb ft). Remove Tooling (B).

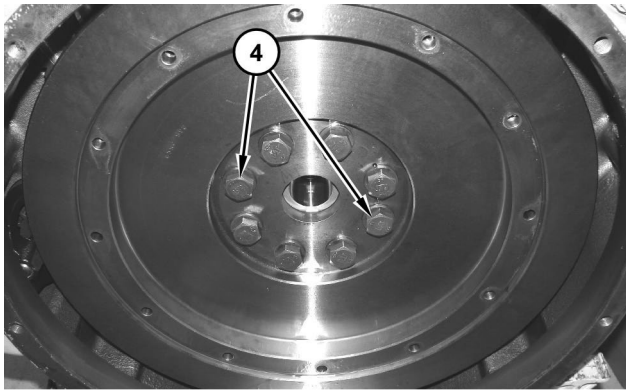

Illustration 313

g01383597

4. Apply Tooling (D) to the remaining bolts (4). Install the remaining bolts (4). Tighten bolts (4) to a torque of $300 \pm 40 \text{ N}\cdot\text{m}$ ($220 \pm 30 \text{ lb ft}$).

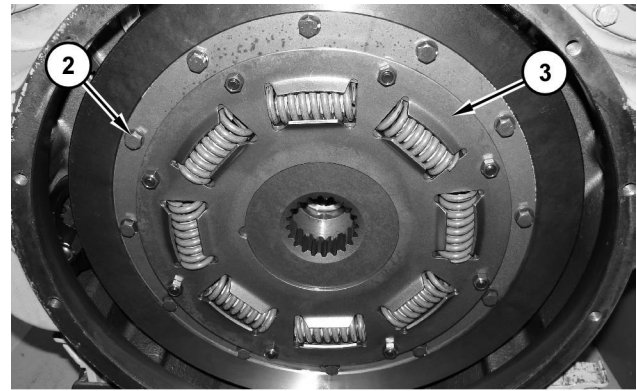

Illustration 314

g01383397

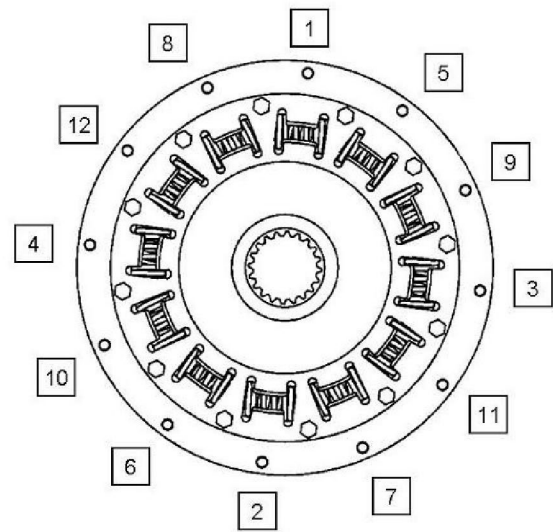

Illustration 315

g02466336

5. Align coupling (3) with the holes in the flywheel. Ensure that coupling (3) is seated properly. Apply Tooling (D) onto bolts (2). Position coupling (3) and install bolts (2). Tighten bolts (2) to an initial torque of $30 \text{ N}\cdot\text{m}$ (22 lb ft) in a diagonal pattern. Tighten bolts (2) again to a torque of $60 \text{ N}\cdot\text{m}$ (44 lb ft) in a diagonal pattern.

End By:

- a. Install the engine.

i05534526

Rear Gear Group - Remove and Install

SMCS Code: 1204-010; 1206-010

Removal Procedure

Table 20

Required Tools			
Tool	Part Number	Part Description	Qty
A	1P-0520	Driver Gp	1
B	1P-0510	Driver Gp	1

Start By:

- a. Remove the flywheel and pump drive gear.

NOTICE

Keep all parts clean from contaminants.

Contaminants may cause rapid wear and shortened component life.

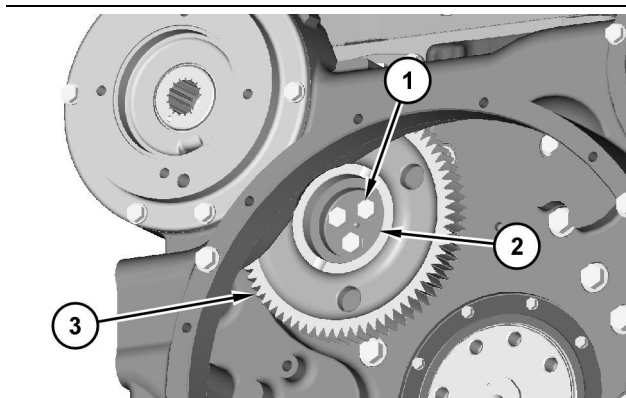

Illustration 316

g01386202

1. Remove bolts (1) and remove retainer (2). Remove gear assembly (3).



Illustration 317

g01383924

2. Use Tooling (A) in order to remove bushing (4) from gear assembly (3).

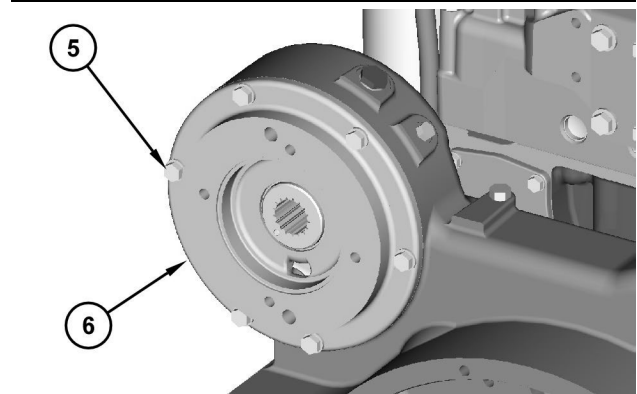

Illustration 318

g01386207

3. Remove bolts (5). Remove adapter (6) and the O-ring seal.

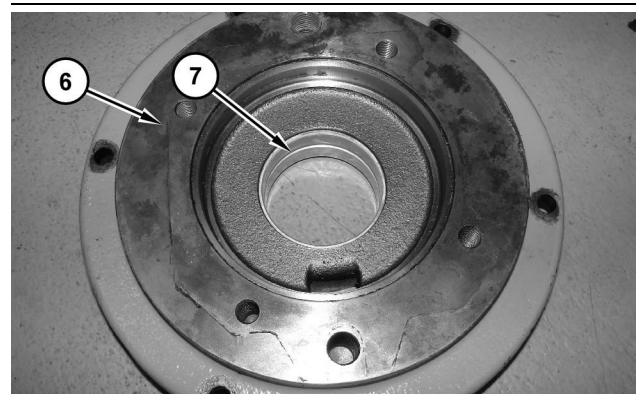

Illustration 319

g01384414

4. Use Tooling (B) in order to remove bearing (7) from adapter assembly (6).

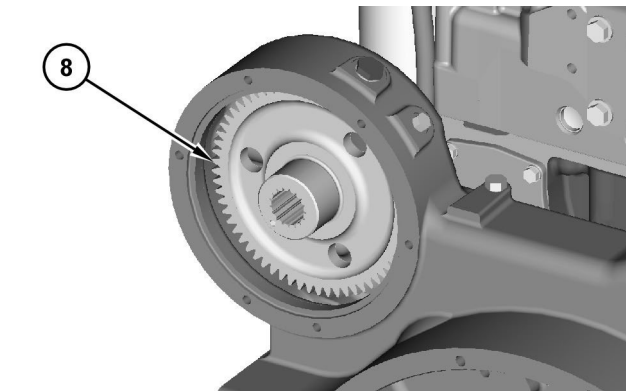

Illustration 320

g01386212

5. Remove gear assembly (8).

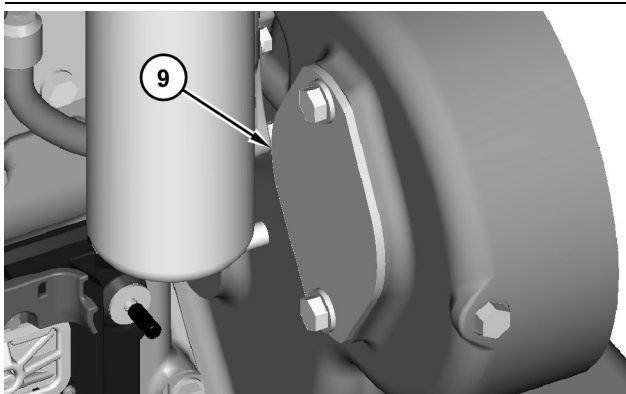

Illustration 321

g01386216

6. Remove cover (9) and the O-ring seal.

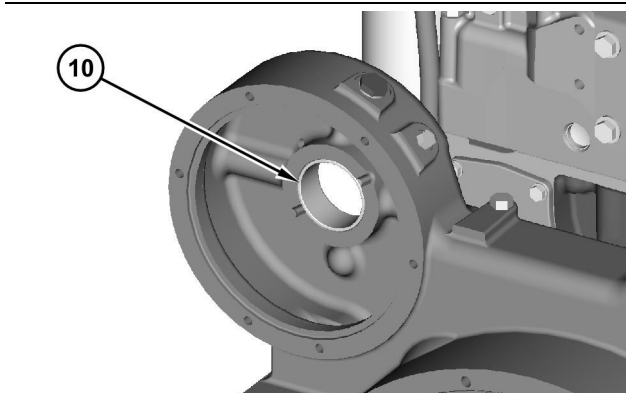

Illustration 322

g01386217

7. Use Tooling (B) in order to remove bearing (10).

Installation Procedure

NOTICE

Keep all parts clean from contaminants.

Contaminants may cause rapid wear and shortened component life.

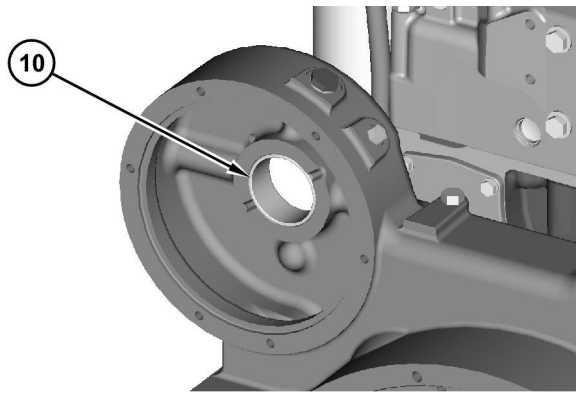

Illustration 323

g01386217



Illustration 324

g01386261

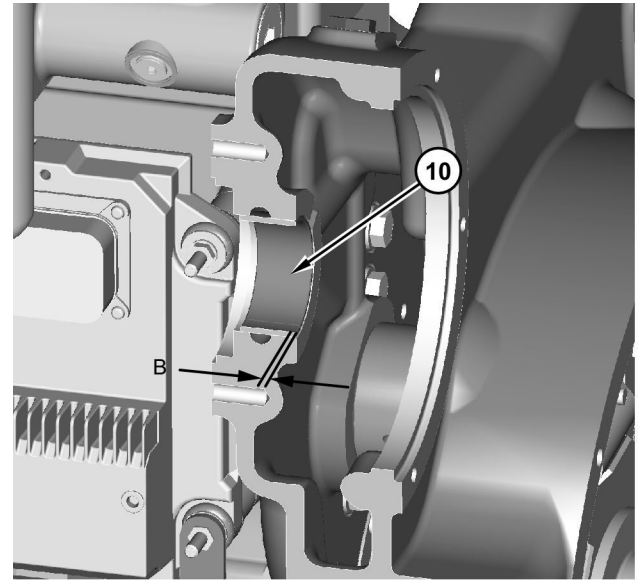

Illustration 325

g02785703

1. Lower the temperature of bearing (10). Be sure to match Dimension (A) and Dimension (B) when you are installing bearing (10). Dimension (A) indicates the angle of the joint on bearing (10). Dimension (A) is $15^\circ \pm 1^\circ$. Dimension (B) shows the distance from bearing (10) to the end of the bore. Dimension (B) is 4.000 ± 0.500 mm (0.1575 ± 0.0197 inch).

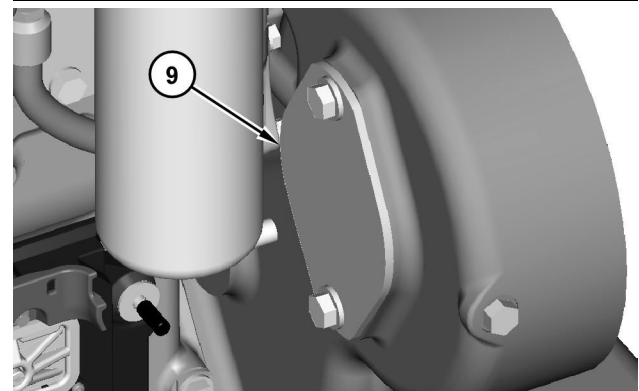

Illustration 326

g01386216

2. Install the O-ring seal and cover (9).

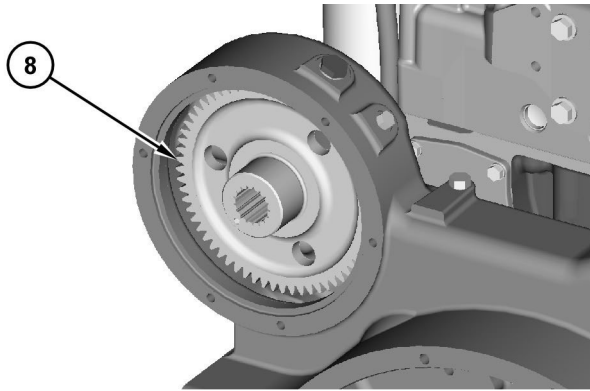

Illustration 327

g01386212

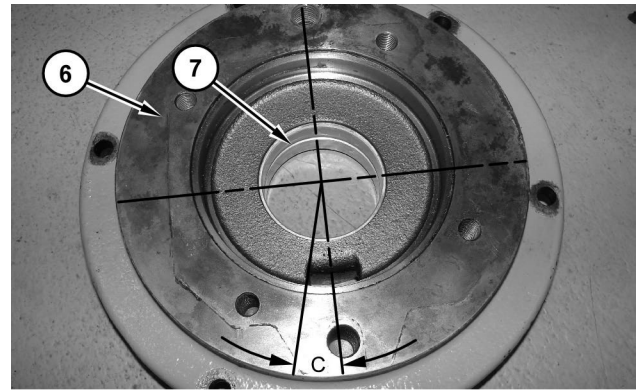

Illustration 328

g01386285

3. Install gear assembly (8). Be sure that the oil passage plug is facing outward.

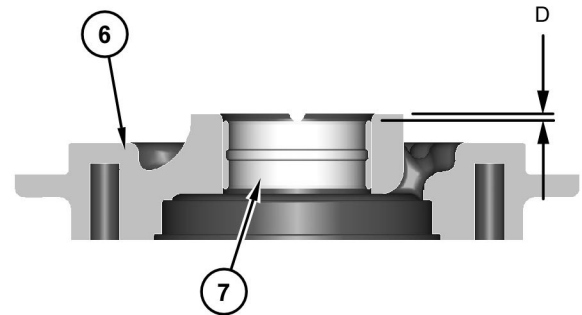

Illustration 329

g01386291

4. Lower the temperature of bearing (7). Be sure to match Dimension (C) and Dimension (D) when you are installing bearing (7) into adapter assembly (6). Dimension (C) indicates the angle of the joint on bearing (7). Dimension (C) is $15^\circ \pm 1^\circ$. Dimension (D) shows the distance from bearing (7) to the end of the bore. Dimension (D) is 3.500 ± 0.500 mm (0.1378 ± 0.0197 inch).

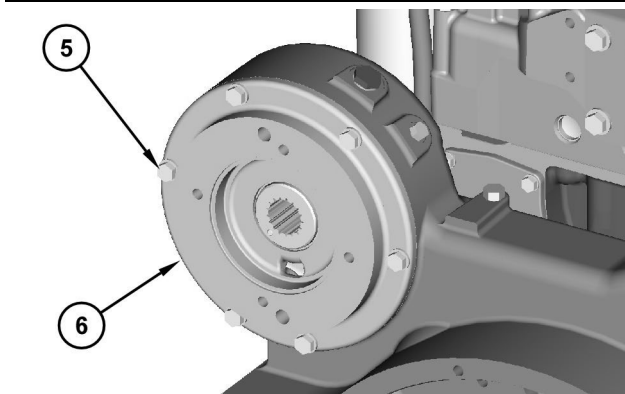

Illustration 330 g01386207

5. Install the O-ring seal and adapter assembly (6). Install bolts (5).

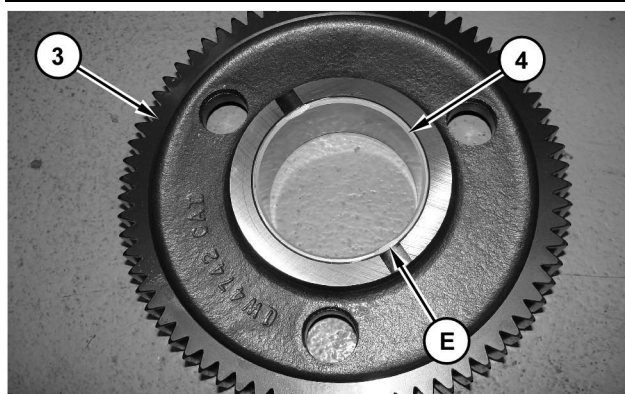

Illustration 331 g01386293

6. Lower the temperature of bearing (4). Install bearing (4) into gear assembly (3). Be sure that each relief (E) in bearing (4) is within 2° of each relief in gear assembly (3).

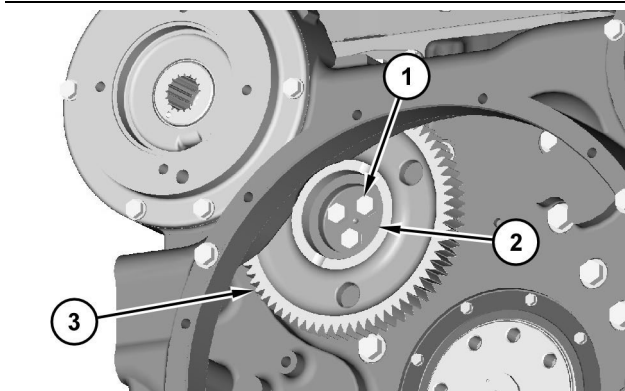

Illustration 332 g01386202

7. Position gear assembly (3) and retainer (2). Install bolts (1).

End By:

a. Install the flywheel and pump drive gear.

i02772963

Flywheel Housing - Remove and Install

SMCS Code: 1157-010

Removal Procedure

Table 21

Required Tools			
Tool	Part Number	Part Description	Qty
A	180-3033	Jack Stand Gp	4
B	138-7575	Link Bracket	2

Start By:

a. Remove the flywheel and pump drive gear. Refer to Disassembly and Assembly, "Flywheel and Rear Gear Group - Remove and Install".

b. Remove the electric starting motor. Refer to Disassembly and Assembly, "Electric Starting Motor - Remove and Install".

NOTICE

Keep all parts clean from contaminants.

Contaminants may cause rapid wear and shortened component life.

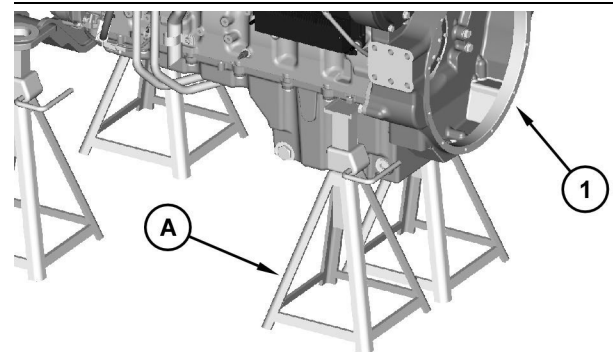

Illustration 333 g01386683

1. Use a suitable lifting device in order to raise engine (1). Position Tooling (A) in order to support engine (1). The weight of engine (1) is approximately 1497 kg (3300 lb).

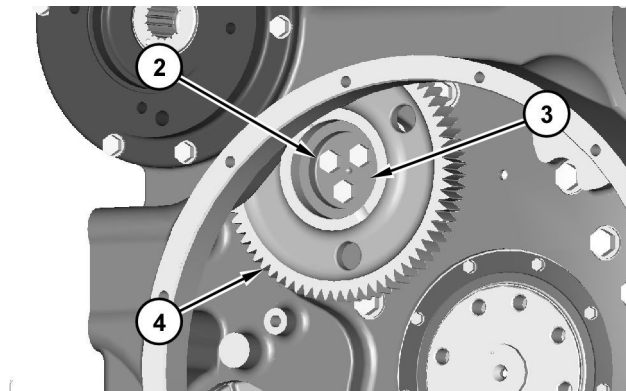

Illustration 334

g01386613

- Remove bolts (2) and retainer (3). Remove gear assembly (4).

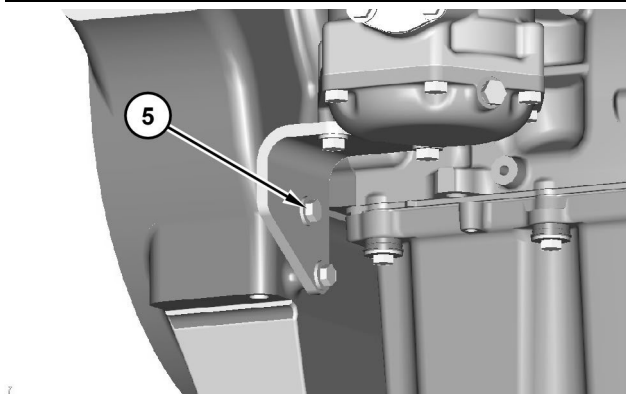

Illustration 335

g01386701

- Remove bolts (5).

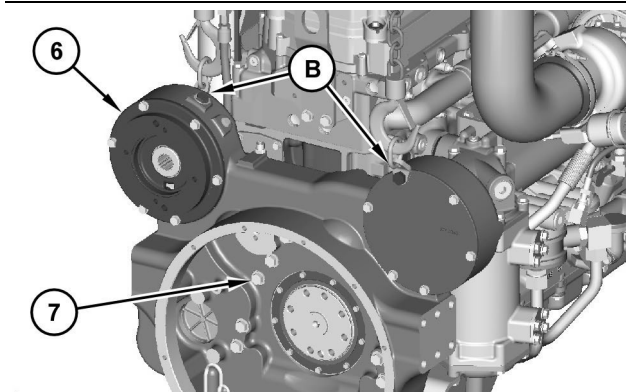

Illustration 336

g01386609

- Attach Tooling (B) and a suitable lifting device to flywheel housing (6). The weight of flywheel housing (6) is approximately 113 kg (250 lb).
- Remove bolts (7). Remove flywheel housing (6).

Installation Procedure

Table 22

Required Tools			
Tool	Part Number	Part Description	Qty
A	180-3033	Jack Stand Gp	4
B	138-7575	Link Bracket	2
C	1U-8846	Gasket Sealant	1

NOTICE

Keep all parts clean from contaminants.

Contaminants may cause rapid wear and shortened component life.

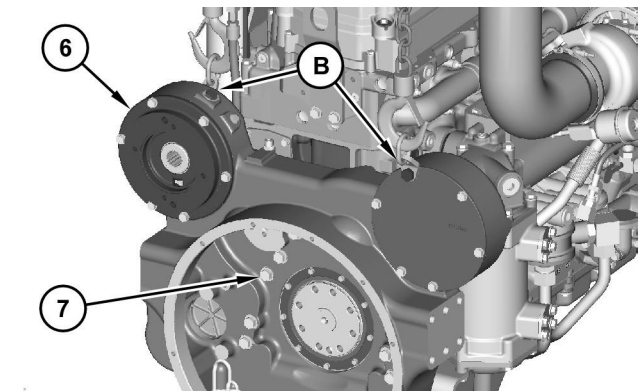

Illustration 337

g01386609

- Apply Tooling (C) onto the entire mounting surface of flywheel housing (6).
- Use Tooling (B) and a suitable lifting device in order to position flywheel housing (6) onto the engine. The weight of flywheel housing (6) is approximately 113 kg (250 lb).
- Install bolts (7).

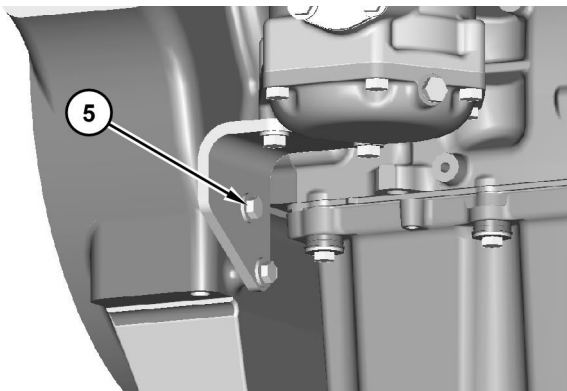

Illustration 338

g01386701

4. Install bolts (5).

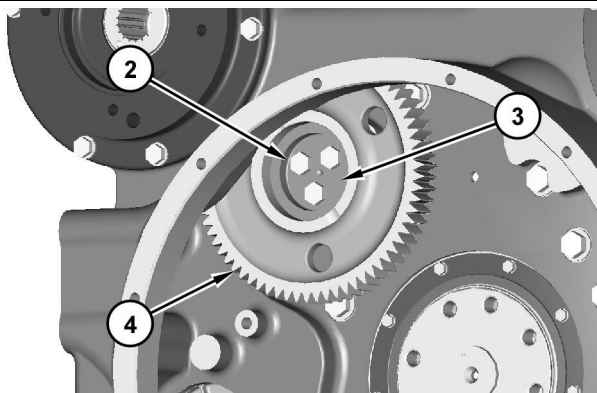

Illustration 339

g01386613

5. Install gear assembly (4). Install retainer (3) and bolts (2).

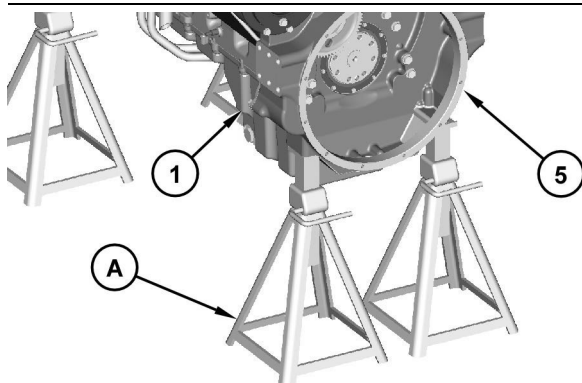

Illustration 340

g01386690

6. Use a suitable lifting device in order to raise engine (1). Position Tooling (A) under flywheel housing (5) in order to support engine (1). The weight of engine (1) is approximately 1497 kg (3300 lb).

End By:

- a. Install the electric starting motor. Refer to Disassembly and Assembly, “Electric Starting Motor - Remove and Install”.
- b. Install the flywheel and pump drive gear. Refer to Disassembly and Assembly, “Flywheel and Rear Gear Group - Remove and Install”.

i02739528

Engine - Remove

SMCS Code: 1000-011

Removal Procedure

Table 23

Required Tools			
Tool	Part Number	Part Description	Qty
A	1U-9200	Lever Puller Hoist	1

Start By:

- a. Remove the fuel tank. Refer to Disassembly and Assembly, “Fuel Tank - Remove”.
- b. Remove the rear chassis support. Refer to Disassembly and Assembly, “Rear Chassis Support - Remove”.
- c. Remove the muffler. Refer to Disassembly and Assembly, “Muffler - Remove and Install”.
- d. Remove the gear pump. Refer to Disassembly and Assembly, “Gear Pump (Transmission Charging and Scavage) - Remove”.
- e. Remove the fan pump. Refer to Disassembly and Assembly, “Piston Pump (Hydraulic Fan) - Remove”.

NOTICE

Care must be taken to ensure that fluids are contained during performance of inspection, maintenance, testing, adjusting, and repair of the product. Be prepared to collect the fluid with suitable containers before opening any compartment or disassembling any component containing fluids.

Refer to Special Publication, NENG2500, “Dealer Service Tool Catalog” for tools and supplies suitable to collect and contain fluids on Cat® products.

Dispose of all fluids according to local regulations and mandates.

⚠ WARNING

Personal injury can result from hydraulic oil pressure and hot oil.

Hydraulic oil pressure can remain in the hydraulic system after the engine has been stopped. Serious injury can be caused if this pressure is not released before any service is done on the hydraulic system.

Make sure all of the work tools have been lowered to the ground, and the oil is cool before removing any components or lines. Remove the oil filler cap only when the engine is stopped, and the filler cap is cool enough to touch with your bare hand.

⚠ WARNING

At operating temperature, the engine coolant is hot and under pressure.

Steam can cause personal injury.

Check the coolant level only after the engine has been stopped and the fill cap is cool enough to touch with your bare hand.

Remove the fill cap slowly to relieve pressure.

Cooling system conditioner contains alkali. Avoid contact with the skin and eyes to prevent personal injury.

NOTICE

Keep all parts clean from contaminants.

Contaminants may cause rapid wear and shortened component life.

Note: Put identification marks on all lines, on all hoses, on all wires, and on all tubes for installation purposes. Plug all lines, hoses, and tubes. This helps to prevent fluid loss and this helps to keep contaminants from entering the system.

1. Drain the engine coolant into a suitable container for storage or disposal. Refer to Operation and Maintenance Manual, "Cooling System Extended Life Coolant - Change".
2. Drain the engine oil into a suitable container for storage or disposal. Refer to Operation and Maintenance Manual, "Engine Oil and Filter - Change".

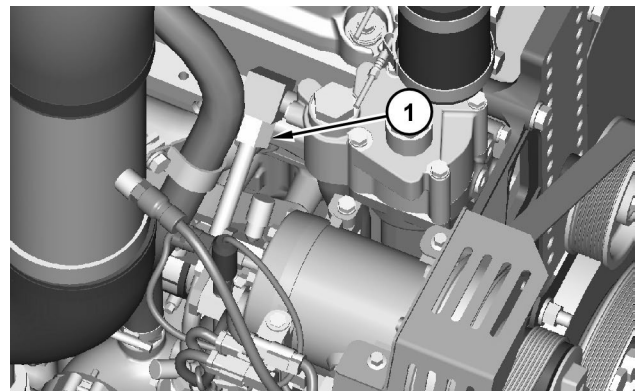

Illustration 341

g01373493

3. Disconnect tube assembly (1).

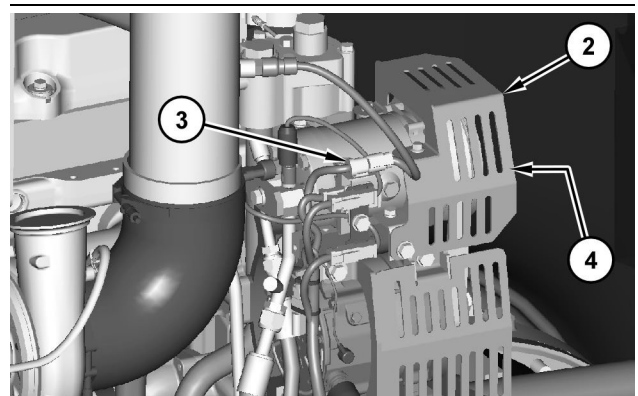

Illustration 342

g01373500

4. Remove guard (2). Disconnect harness assembly (3).
5. Remove belt (4). Refer to Operation and Maintenance Manual, "Belt - Replace".

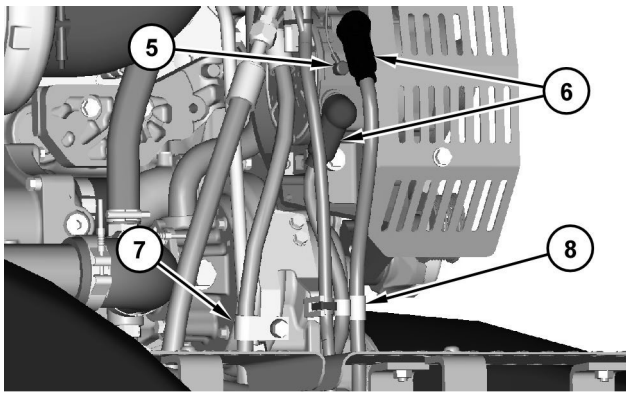

Illustration 343 g01373510

6. Disconnect harness assembly (5). Disconnect cable assemblies (6). Remove clips (7) and clips (8).

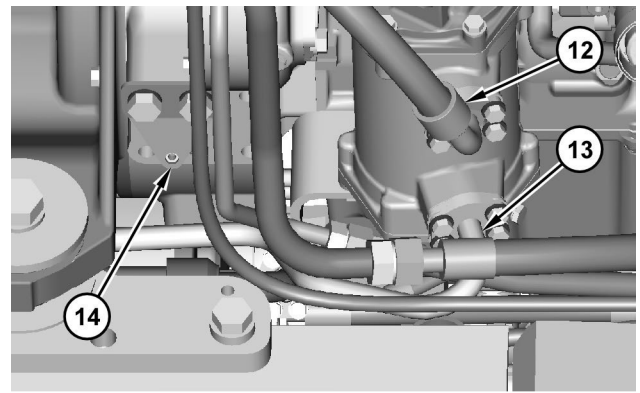

Illustration 346 g01373527

9. Disconnect hose assembly (12). Disconnect tube assembly (13). Remove bracket (14).

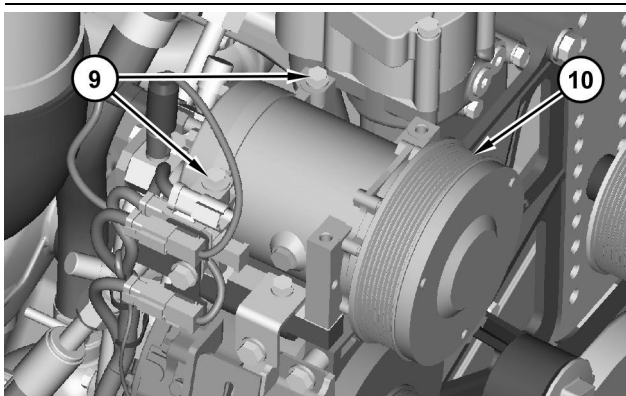

Illustration 344 g01373513

7. Remove bolts (9). Position refrigerant compressor (10) out of the way.

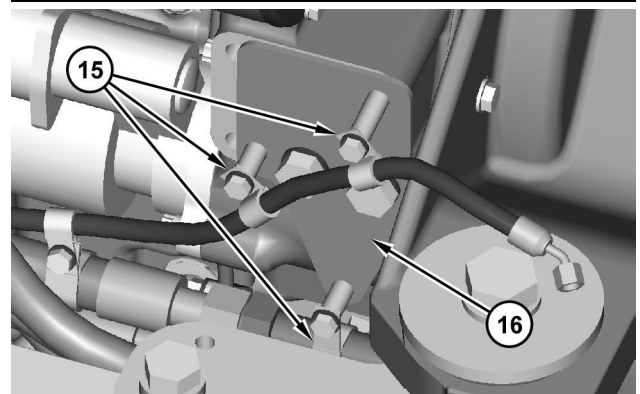

Illustration 347 g01373589

10. Remove clips (15). Remove bracket (16).

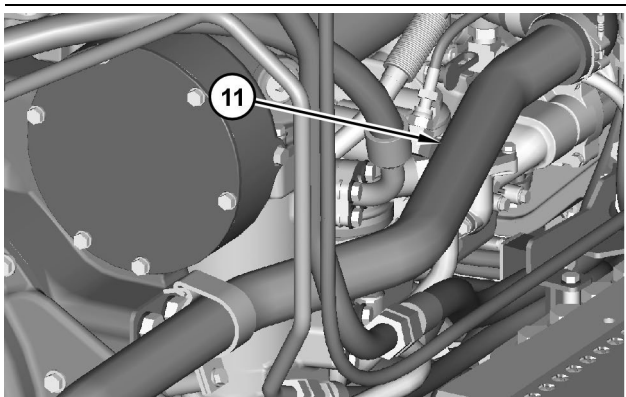

Illustration 345 g01373586

8. Remove tube (11).

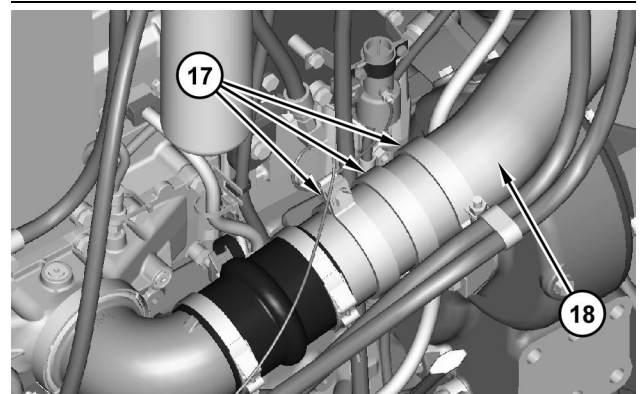

Illustration 348 g01373596

11. Remove clamps (17). Remove tube (18).

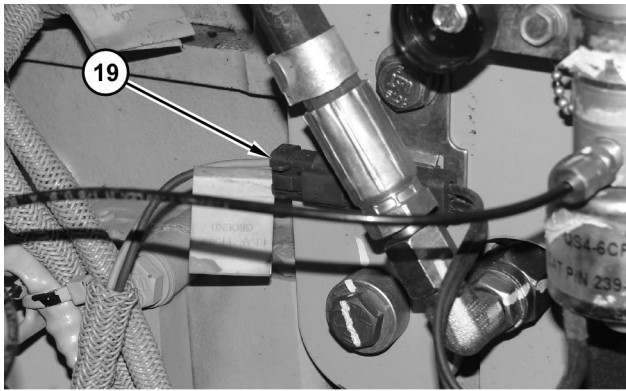

Illustration 349

g01373614

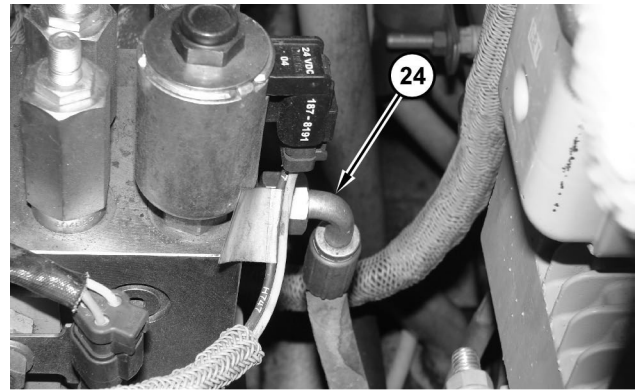

Illustration 352

g01373628

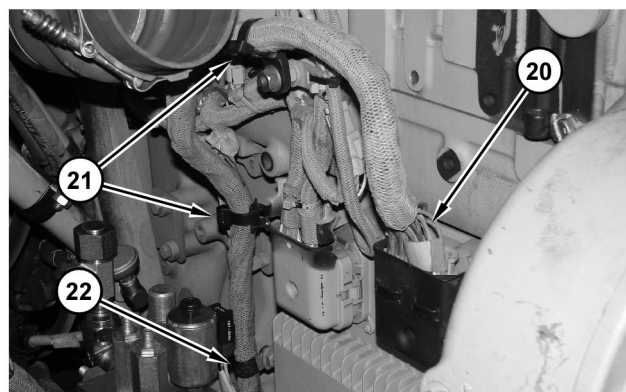

Illustration 350

g01373618

12. Disconnect harness assembly (19). Disconnect harness assembly (20). Remove cable straps (21). Remove clip (22).

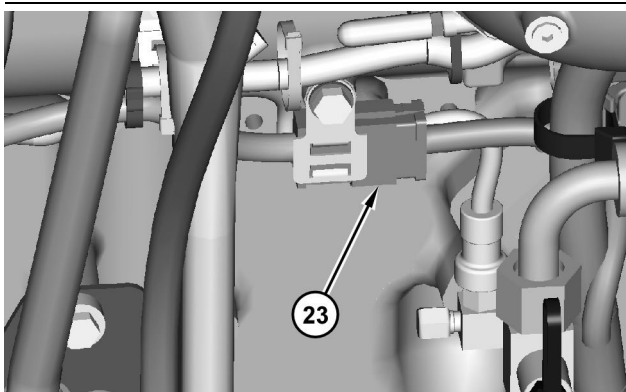

Illustration 351

g01373652

13. Disconnect harness assembly (23).

14. Disconnect hose assembly (24).

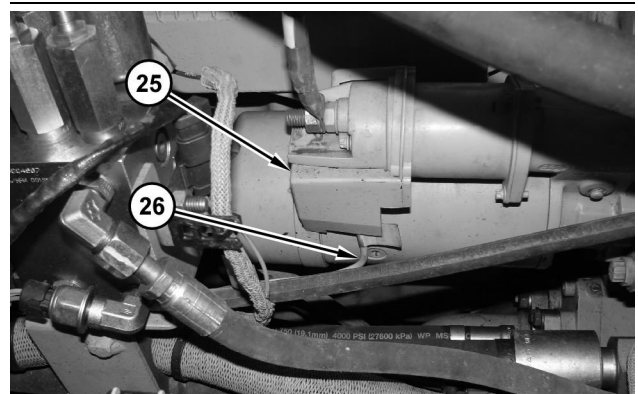

Illustration 353

g01373632

15. Remove cover (25). Disconnect harness assembly (26).

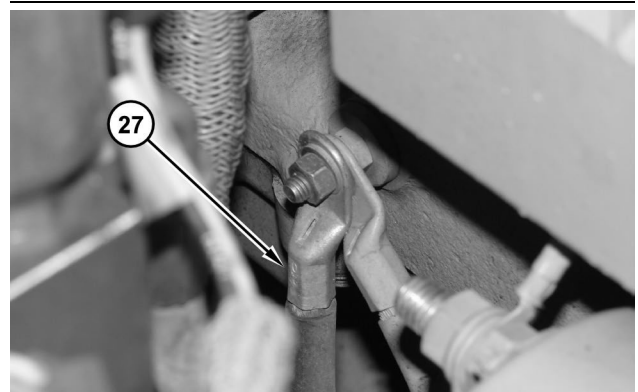

Illustration 354

g01373637

16. Disconnect cable assembly (27).

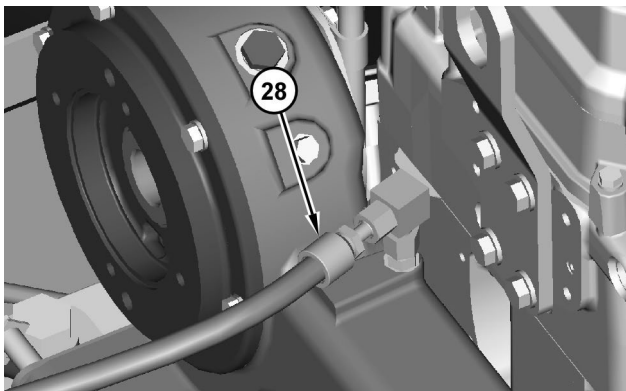

Illustration 355 g01373640

17. Disconnect hose assembly (28).

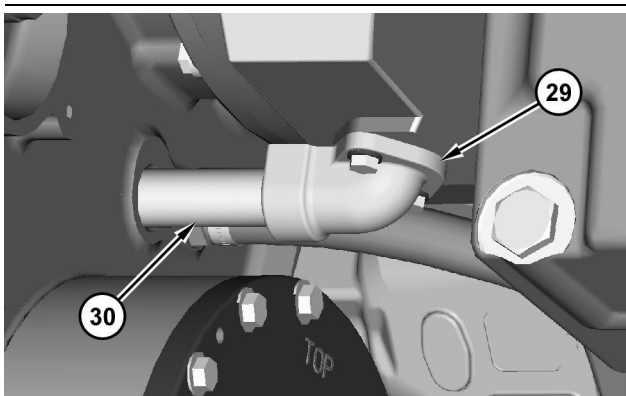

Illustration 356 g01373642

18. Remove elbow (29). Remove tube (30).

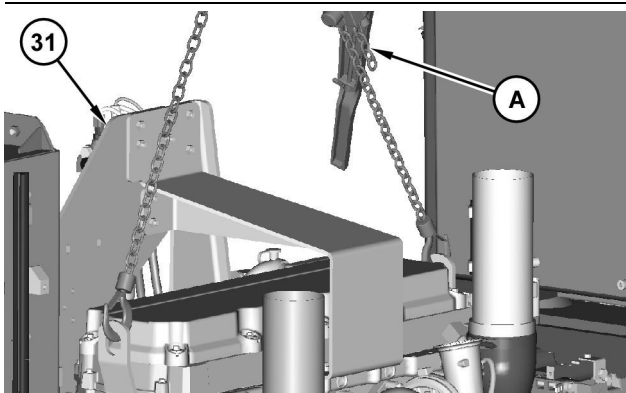

Illustration 357 g01373646

19. Attach Tooling (A) and a suitable lifting device onto engine (31). The weight of engine (31) is approximately 1497 kg (3300 lb).

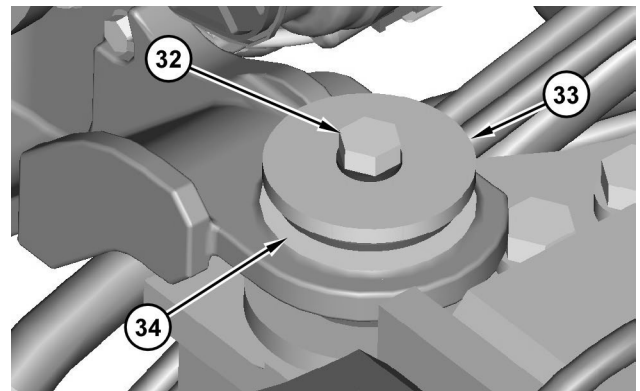

Illustration 358 g01373766

20. Remove bolt (32), washer (33), and pad (34). Repeat this step for the opposite side.

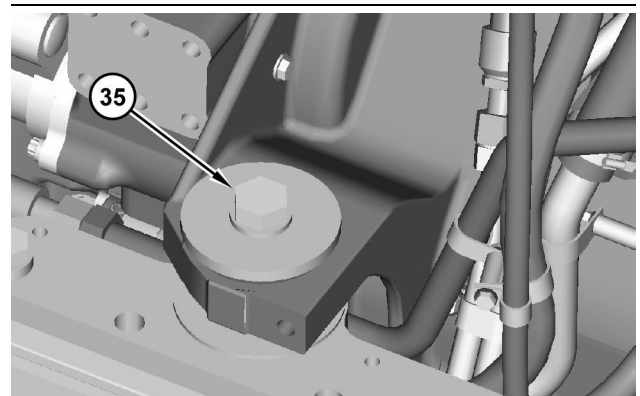

Illustration 359 g01373770

21. Loosen bolts (35). Repeat this step for the opposite side.

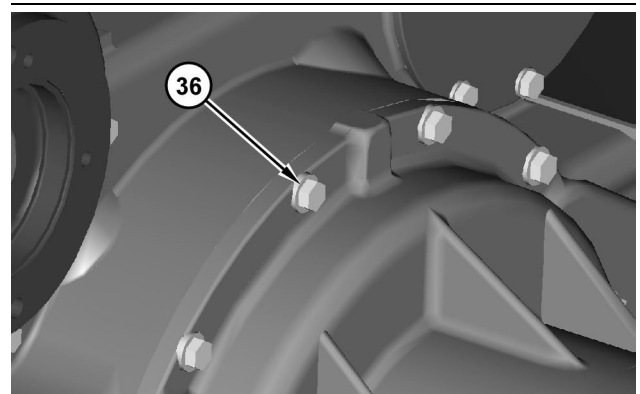

Illustration 360 g01373772

22. Remove bolts (36).

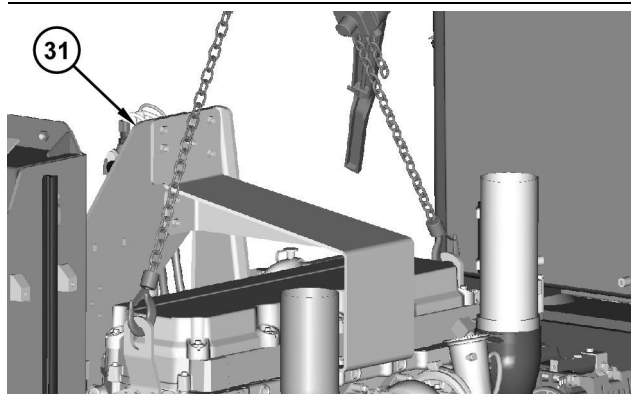

Illustration 361

g01373774

23. Remove engine (31).

i02739546

Engine - Install

SMCS Code: 1000-012

Installation Procedure

Table 24

Required Tools			
Tool	Part Number	Part Description	Qty
A	1U-9200	Lever Puller Hoist	1
B	1U-9754	Hydraulic Jack	1

NOTICE

Keep all parts clean from contaminants.

Contaminants may cause rapid wear and shortened component life.



Illustration 362

g01331794

1. Use Tooling (B) in order to raise the transmission.

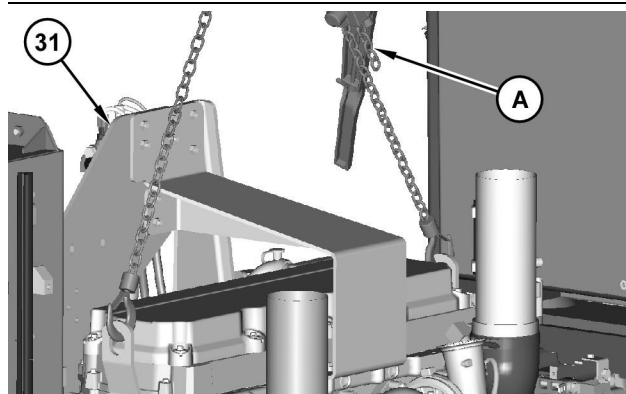

Illustration 363

g01373646

2. Use Tooling (A) and a suitable lifting device in order to install engine (31). The weight of engine (31) is approximately 1497 kg (3300 lb).

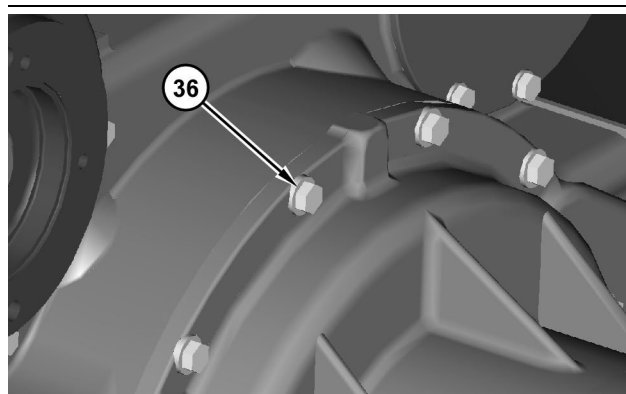

Illustration 364

g01373772

3. Install bolts (36).

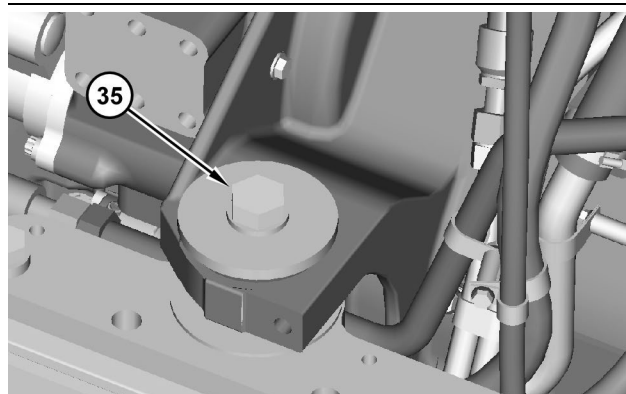

Illustration 365

g01373770

4. Tighten bolt (35). Repeat this step for the opposite side.

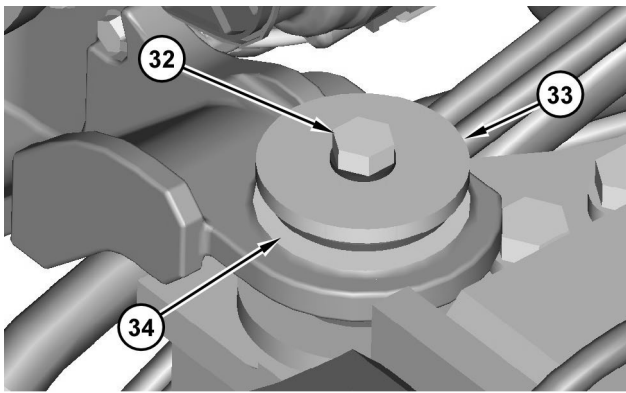

Illustration 366

g01373766

5. Install pad (34), washer (33), and bolt (32). Repeat this step for the opposite side.

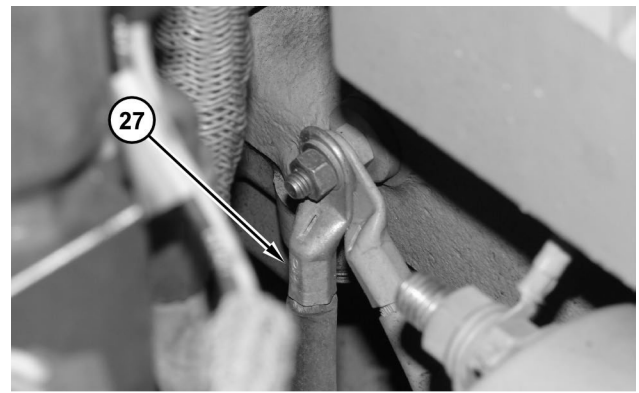

Illustration 369

g01373637

8. Connect cable assembly (27).

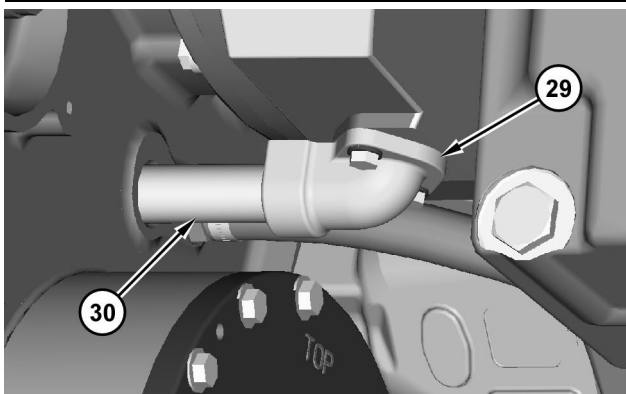

Illustration 367

g01373642

6. Install tube (30). Install elbow (29).

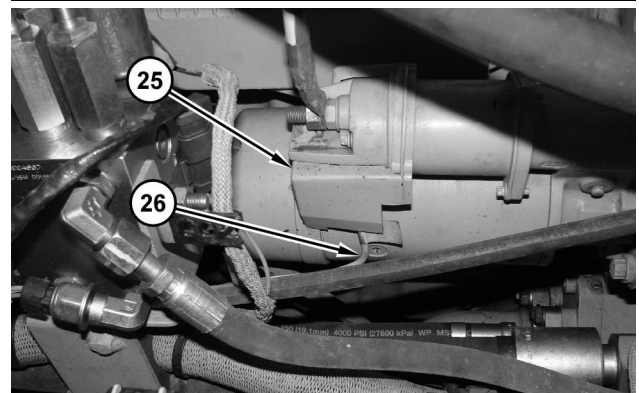

Illustration 370

g01373632

9. Connect harness assembly (26). Install cover (25).

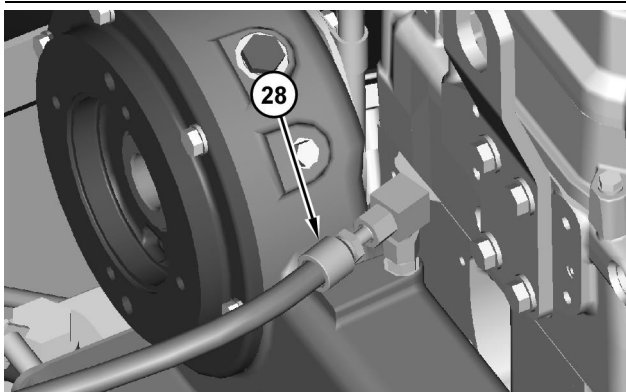

Illustration 368

g01373640

7. Connect hose assembly (28).

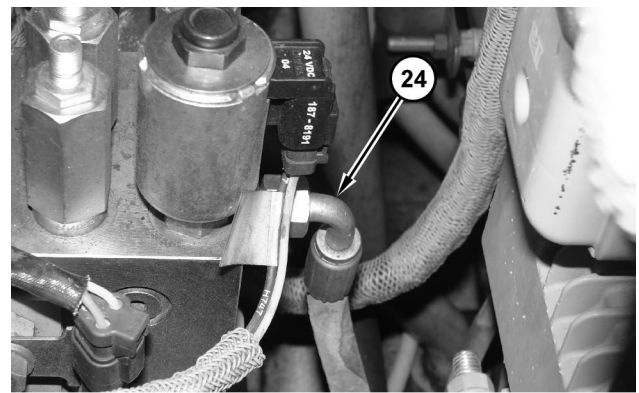

Illustration 371

g01373628

10. Connect hose assembly (24).

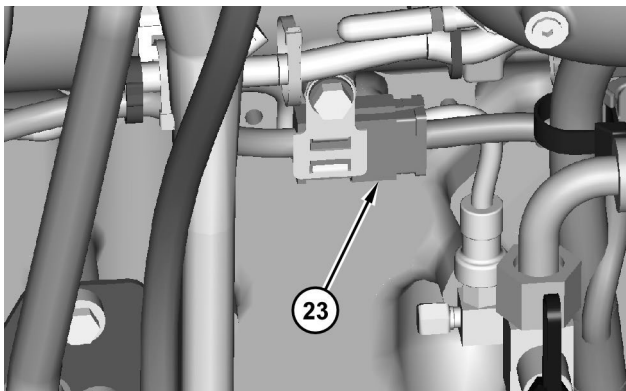

Illustration 372

g01373652

11. Connect harness assembly (23).

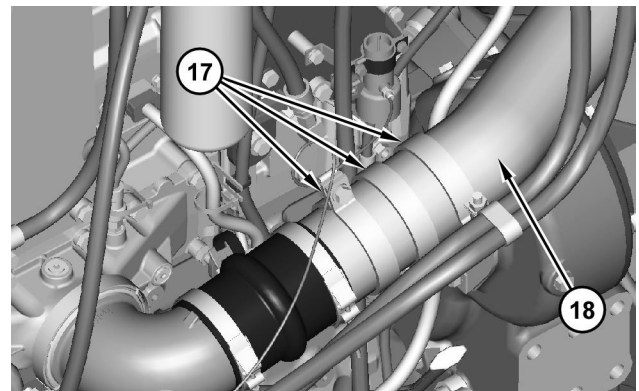

Illustration 375

g01373596

13. Install tube (18). Install clamps (17).



Illustration 373

g01373614

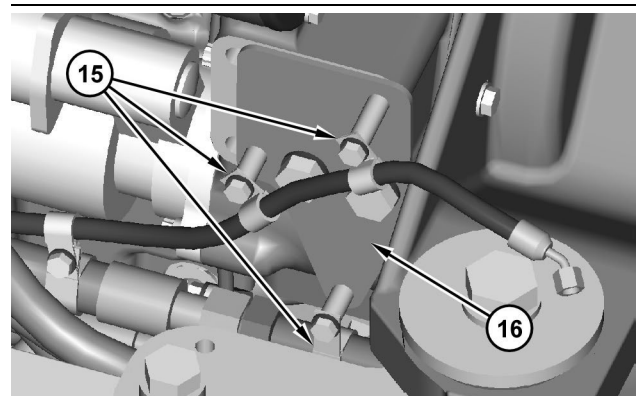

Illustration 376

g01373589

14. Install bracket (16). Install clips (15).

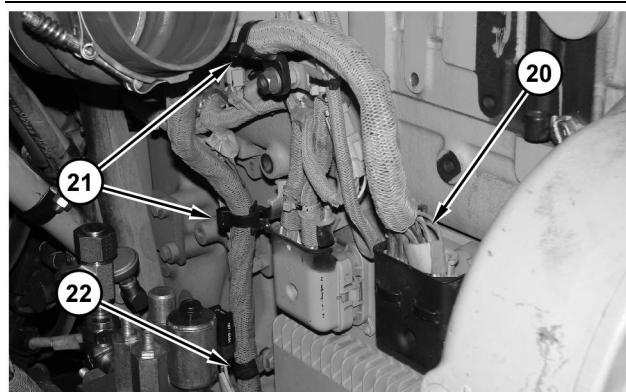

Illustration 374

g01373618

12. Install clip (22). Install cable straps (21). Connect harness assembly (20). Connect harness assembly (19).

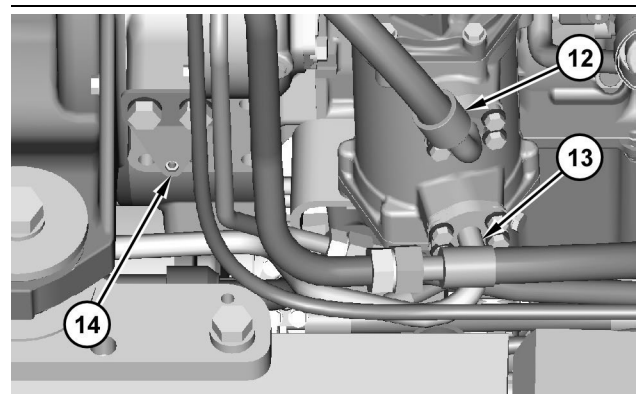

Illustration 377

g01373527

15. Install bracket (14). Connect tube assembly (13). Connect hose assembly (12).

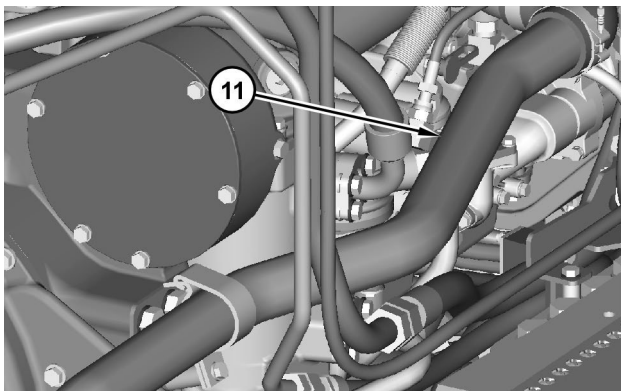

Illustration 378

g01373586

16. Install tube (11).

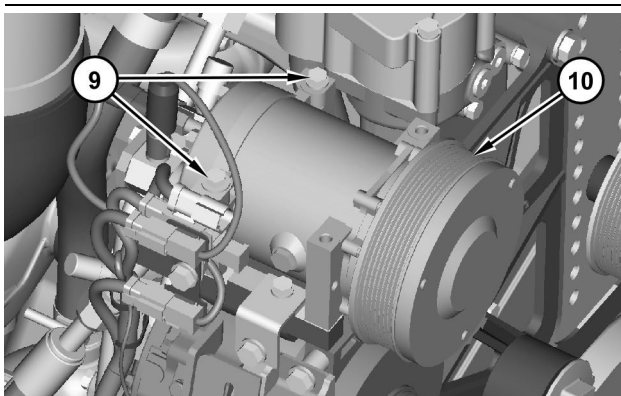

Illustration 379

g01373513

17. Position refrigerant compressor (10) and install bolts (9).

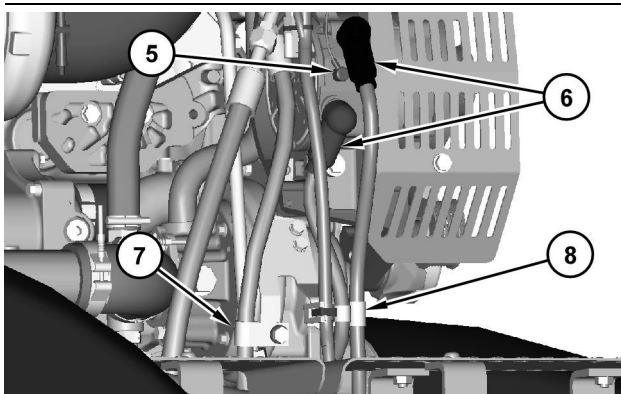

Illustration 380

g01373510

18. Install clips (8) and clips (7). Connect cable assemblies (6). Connect harness assembly (5).

19. Install belt (4). Refer to Operation and Maintenance Manual, "Belt - Replace".

20. Connect harness assembly (3). Install guard (2).

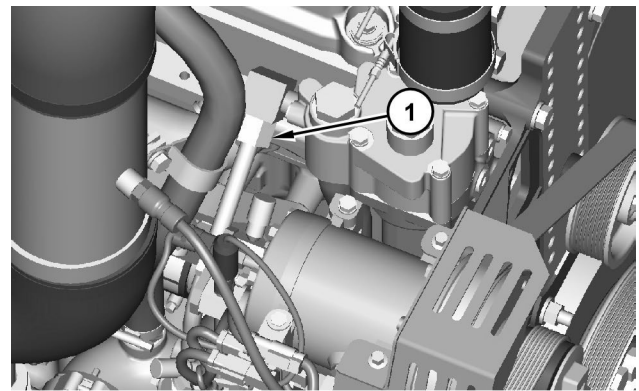

Illustration 381

g01373493

21. Connect tube assembly (1).

22. Fill the engine with engine oil. Refer to Operation and Maintenance Manual, "Engine Oil and Filter - Change".

23. Fill the engine cooling system. Refer to Operation and Maintenance Manual, "Cooling System Extended Life Coolant - Change".

End By:

a. Install the fan pump. Refer to Disassembly and Assembly, "Piston Pump (Hdraulic Fan) - Install".

b. Install the gear pump. Refer to Disassembly and Assembly, "Gear Pump (Transmission Charging and Scavage) - Remove".

c. Install the muffler. Refer to Disassembly and Assembly, "Muffler - Remove and Install".

d. Install the rear chassis support. Refer to Disassembly and Assembly, "Rear Chassis Support - Install".

Index

A

Aftercooler - Remove and Install.....	55
Installation Procedure	57
Removal Procedure	55
Air Cleaner - Remove and Install	12
Installation Procedure	12
Removal Procedure	12
Alternator - Remove and Install	15
Installation Procedure	16
Removal Procedure	15

B

Battery - Remove and Install	4
Installation Procedure	4
Removal Procedure	4

D

Disassembly and Assembly Section	4
--	---

E

Electric Starting Motor - Remove and Install	49
Installation Procedure	50
Removal Procedure	49
Engine - Install	88
Installation Procedure	88
Engine - Remove	83
Removal Procedure	83
Engine Enclosure (Hood) - Install	8
Installation Procedure	8
Engine Enclosure (Hood) - Remove	5
Removal Procedure	5
Engine Oil Cooler - Remove and Install.....	40
Installation Procedure	41
Removal Procedure	40
Engine Oil Filter Base - Assemble	36
Assembly Procedure	36
Engine Oil Filter Base - Disassemble	35
Disassembly Procedure	35
Engine Oil Filter Base - Install	38
Installation Procedure	38
Engine Oil Filter Base - Remove.....	33
Removal Procedure	33
Engine Support (Front) - Remove and Install	19
Installation Procedure	20
Removal Procedure	19

F

Flywheel and Rear Gear Group - Remove and Install (Drive Gear)	73
Installation Procedure	75
Removal Procedure	73
Flywheel Housing - Remove and Install.....	81
Installation Procedure	82
Removal Procedure	81
Fuel Filter (Secondary) and Fuel Filter Base - Remove and Install.....	48
Installation Procedure	49
Removal Procedure	48

Fuel Priming Pump and Water Separator - Remove and Install	42
Installation Procedure	43
Removal Procedure	42
Fuel Transfer Pump - Remove and Install.....	31
Installation Procedure	32
Removal Procedure	31

I

Important Safety Information	2
------------------------------------	---

M

Muffler - Remove and Install.....	14
Installation Procedure	15
Removal Procedure	14

R

Radiator - Install.....	64
Installation Procedure	64
Radiator - Remove	62
Removal Procedure	62
Radiator Guard and Support, Aftercooler, Hydraulic Oil Cooler, and Radiator - Remove	52
Removal Procedure	52
Radiator Guard and Support, Aftercooler, Hydraulic Oil Cooler, and Radiator, - Install	59
Installation Procedure	59
Rear Chassis Support - Install	70
Installation Procedure	70
Rear Chassis Support - Remove	66
Removal Procedure	66
Rear Gear Group - Remove and Install	77
Installation Procedure	78
Removal Procedure	77
Refrigerant Compressor - Remove and Install	21
Installation Procedure	23
Removal Procedure	21
Refrigerant Condenser - Install.....	28
Installation Procedure	28
Refrigerant Condenser - Remove	24
Removal Procedure	24

T

Table of Contents	3
Turbocharger - Remove and Install.....	13
Installation Procedure	14
Removal Procedure	13

V

Vibration Damper and Pulley - Remove and Install	17
Installation Procedure	18
Removal Procedure	17

W

Water Pump - Install	46
----------------------------	----

Installation Procedure46
Water Pump - Remove43
Removal Procedure43

